

## ANNEXURE

### STATE BOARD OF TECHNICAL EDUCATION & TRAINING, TAMILNADU DIPLOMA IN ENGINEERING / TECHNOLOGY SYLLABUS M-SCHEME

**(Implements from the Academic year 2015-2016 onwards)**

Course Name : All branches of Diploma in Engineering and Technology and Special Programmes except HMCT and film & TV.

Subject Code : 30011

Semester : I Semester

Subject Title : **COMMUNICATION ENGLISH – I**

#### **TRAINING AND SCHEME OF EXAMINATION:**

No. of Weeks per Semester: 15 Weeks

Subject	Instructions		Examination			Duration
	Hours / Week	Hours / Semester	Marks			
Communication English - I	5 Hrs.	75 Hrs.	Internal Assessment	Semester Examination	Total	3 Hrs
			25	75	100	

#### **RATIONALE**

With the increasing variety of options and opportunities emerging for Diploma students, fulfilling their communication needs become highly important. Proficiency in communication can equip them to be confident and to cope with the employment and educational situation in any part of the world. Communication levels inspire higher aspiratory levels in the process of upward mobility in career and socio-cultural evolution of the young individuals. At the end of the course the student should be able to express himself in oral and written communication effectively.

#### **SPECIFIC INSTRUCTIONAL OBJECTIVES**

All the four skills - listening, speaking, reading and writing - should be developed in the communication process for a polytechnic student who is at the intermediate level and transitional period from school to college.

Silent reading of the English text book acquaints him with the grammatical structures and the nuances of the language indirectly and also triggers reaction in the thinking process according to the student's specific learning background. Loud

reading equips the student with confidence and practice for oral communication. Both these should be given due importance in the class room situation.

Developing listening skills equip them with the necessary focus in understanding oral communication without difficulty to react and interact properly. Proper exposure in developing these two skills facilitates speaking and writing which are very essential in day to day interaction in any official, social or personal context. Matching to the entry level quality of the polytechnic student and his technical background, this text book is aimed at fulfilling the needs of all the four communication skills with suitable texts, language exercises and activities.

Grammar items prescribed in the syllabus are embedded in the prescribed texts to make the teaching learning process contextualised and activity based to ensure proper textual orientation. Exercises and group activities are given in the text itself for the students to get practiced.

### **30011 COMMUNICATION ENGLISH – I**

#### **DETAILED SYLLABUS**

#### **Contents: Theory**

<b>Content</b>	<b>Competencies</b>	<b>Transactional Strategies</b>	<b>Learning Outcomes</b>	<b>Contact Hrs.</b>
<b>Unit I</b>  <b>Names &amp; Actions</b>	Grammar  <b>Nouns &amp; Verbs</b>	Through Activities  Presentation: Practice: Use Presentation of Rules Adequate Contextual examples Practice	Identify nouns & Verbs Distinguish & use singular & plural nouns Differentiate tense (time) from verbs (actions) Learn tense using timelines	7
	Listening  <b>Plurals, past tense endings</b>	Activities to sensitize Pronunciation of Plurals & Past tense verbs endings  Activities: homophones	Distinguish the Pronunciation of Past tense & Plural endings  Recognize words with similar pronunciation but different spelling & meanings	4
	Reading	Task based: Factual, Inferential Vocabulary & Experiential questions	Comprehend & respond to simple texts	4

<b>Unit 2</b>  <b>Description &amp; Connections</b>	Grammar  <b>Adjectives &amp; Prepositions</b>	Through activities  Presentation: Practice: use Presentation of rules Adequate contextual examples Practice	Recognize adjectives Transform adjectival forms (Word level) Compare prepositions & use them in context Use adjectives & prepositions productively in speech and writing	6
	Listening	Activities Rhyming sounds Homophones	Identify and use appropriate pronunciation	4
	Speaking & Writing	Activities: Pair work, individual Work	Introduce themselves & describe friends using adjectives	2
	Reading	Task based Factual, Inferential Vocabulary & Experiential questions	Comprehend, interpret & analyze simple reading passages	3
<b>Unit 3</b>  <b>Resources &amp; Environment</b>	Grammar  <b>Kinds of sentences</b> <b>Phrases, clauses</b> <b>sentences</b> <b>Negative sentences</b> <b>Articles</b>	Through Activities  Presentation, Practice, Use Presentation of Rules Adequate contextual practice	Recognize kinds of sentences Convert sentences as directed Differentiate phrases, clauses, sentences, Use articles Identify & use negative sentences	7
	Listening	Activities Homophones	Distinguish & use words with similar pronunciation	2
	Reading	Task based: Factual, Inferential Vocabulary & Experiential questions	Draft main points Comprehend, interpret & analyze small passages	4
	Writing <b>Punctuation</b>	Activity	Use Capitals, Commas & Periods	2

<b>Unit 4</b>	<p>Writing</p> <p><b>Visual to Verbal Paragraph (using linkers) Messages</b></p>	<p>5-step writing process</p> <ul style="list-style-type: none"> <li>• Pre-writing (brainstorming )</li> <li>• Clustering/grouping ideas</li> <li>• Rough draft</li> <li>• Revision/editing</li> <li>• Final draft</li> </ul> <p>Activities/tasks</p>	<p>Interpret visuals</p> <p>Brainstorm, organize &amp; write paragraphs using linkers</p> <p>Write messages for given contexts</p>	15
<b>Unit 5</b>	<p>Writing</p> <p><b>Ads Personal letters [Invitation, Permission &amp; thanking] Develop hints</b></p>	<p>Activities/ tasks (sample, guided controlled, free)]</p>	<p>Develop hints</p> <p>Write ads</p> <p>Identify &amp; compose personal letters for different purposes</p>	15
	<p>Reading</p>	<p>Task based: Factual, Inferential Vocabulary &amp; Experiential questions</p>	<p>Comprehend, interpret &amp; analyze texts</p>	

## MODEL QUESTION PAPER

### SEMESTER – I

Time: 3 Hours

Maximum Marks: 75

I. Answer any ten of the following:

10 X 3 = 30

1. Find the odd word in each group according to pronunciation.

- a) Wood, would, mood, could
- b) Shut, cut, mutt, put
- c) Walked, talked, mocked, planted

2. Identify short and long sounds and write “short” or “long” next to each word.

- a) bit ---                      b) sleep ---                      c) pool ---
- d) beat ---                      e) pull ----                      f) slip ----

3. Fill in the blanks with the suitable word from the homophones given in brackets.

- a) He asked the conductor what the bus \_\_\_\_ was. (fair / fare)
- b) The convict was put in the \_\_\_\_\_. (cell /sell)
- c) The passengers use the \_\_\_\_\_ as the escalators do not function.  
(Stairs/stares)

4. Fill in the blanks with plural form of the word given in the bracket.

- a) A porter carries tiffin \_\_\_\_\_ (box).
- b) They travel by different \_\_\_\_\_ (mode) of transport.
- c) The farmers buy \_\_\_\_\_ (cow) in the market.

5. Find the odd word based on the verb form.

- a) made, play, make, plan
- b) sell, help, tell, hell
- c) would, might, should, fight

6. Identify the tense forms used in the following sentences.

- a) I am writing the examination now.
- b) I like sweets.
- c) I went to Chennai last week.

7. Identify three naming words in the following sentence

Raju went to the library to collect the books from the clerk.

8. Identify three action words in the following sentence

He took a piece of paper, wrote a poem and read it to the class.

**9. Fill in the blanks with appropriate adjectives given in brackets.**

- a) I wear a \_\_\_\_\_ ( white / pure ) shirt.
- b) They like to read \_\_\_\_\_ ( comic / comedy ) books.
- c) People prefer to travel by \_\_\_\_\_ ( locale / local ) trains.

**10. Fill in the blanks with suitable prepositions.**

- a) The college begins \_\_\_\_ (on / at) 8.30 A.M every day.
- b) My birthday falls \_\_\_\_ (on / in) 10<sup>th</sup> July.
- c) I was born \_\_\_\_ (in / on) 1990.

**11. Fill in the blanks with suitable articles in the following sentences.**

- a) Gopinath is \_\_\_\_ enterprising person.
- b) Ooty is \_\_\_\_ tourist spot.
- c) My mother goes to \_\_\_\_ market.

**12. Correct the Spelling.**

1. apearans 2. sindetic 3. treetmend

**II. Answer any five of the following.**

**5x3=15**

**1. Underline the main clause in the following sentences.**

- a) As soon as the teacher entered the class, the students greeted her.
- b) Being sick, I did not attend the meeting.
- c) Though he was an orator, he did not deliver an impressive speech.

**2. Underline the subordinate clause in the following sentences.**

- a) I met the girl who had helped me.
- b) I bought a table that costs Rs.1000.
- c) As he is suffering from a fever, he goes to meet the doctor.

**3. Rearrange the jumbled words into meaningful sentences**

- a) a, writes, in, Kumar, the, room, class, letter.
- b) learn, the, grammar, students.
- c) doctor, kala, an, is, efficient.

**4. Frame questions for the following responses**

- a) The rainbow looks very beautiful.
- b) I met my friend in his college.
- c) The Class will start at 9 O' clock.

**5. Convert the statements into exclamatory sentences.**

- a) The tiger is a very ferocious animal.
- b) His handwriting is very good.
- c) The moon is very bright today.

**6. Punctuate and use capital letters wherever necessary:**

- a) ram is in london at present
- b) when sheela wants to buy a house her husband objects
- c) our parliament is in new delhi

**7. A man approaches you to direct him to a nearby hospital. Give three directions using imperative form.**

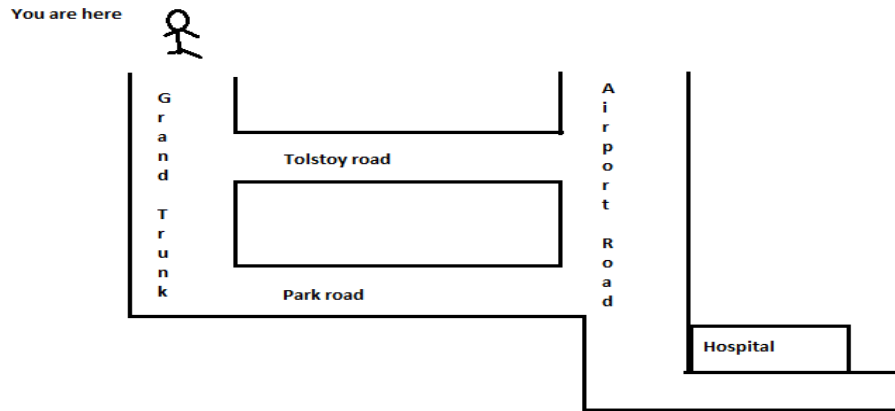

**III. Answer the following**

**3 x 5 = 15**

**1. Read the questions and find answers in the given paragraph.**

- a) Who is Sona to the speaker of this passage?
- b) Does Sona study?
- c) How old is Sona?
- d) Describe Sona's appearance.
- e) What is your opinion of Sona?

**SONA**

My niece Sona is an adorable girl. She is five years old, but is tall for her age. She has curly, dark black hair and black eyes. When she smiles, her little white teeth seem to light up her face. Sona is also a friendly girl. She is always playing funny jokes on people to make them laugh. She likes to talk a lot to show how smart she is. She is always eager to recite lessons or poems. Finally, my niece Sona is a very

active little girl. She goes to nursery school every day, and she loves to play. She plays ball in the yard with her friends after school. Other times, she likes to play quietly with her Barbie dolls. I love my little niece, Sona and if you saw her you would love her, too.

**2. a) Describe a “market” (5 sentences)**

**OR**

**b) Write your experience on the first day in a polytechnic college (5 sentences).**

**3. Write a letter to your friend inviting him for your birthday celebrations to be arranged at your home.**

**IV. Answer any three of the following.**

**3 x 5 = 15**

**1. Write a short message to your friend about being late to college as you have missed the bus because of the traffic in your area.**

**2. Study the visual carefully and write five sentences:**



**3. Fill up the blanks by choosing the suitable linkers given in brackets.**

**(then, thus, and, because, so)**

Yesterday I was working in my office without break for tea, even after 5 P.M. The time was 6.00 P.M. I felt so tired \_\_\_\_ of it. \_\_\_\_, I went to a restaurant and had a cup of coffee. \_\_\_\_, I went for a walk \_\_\_\_ later resumed my work in the office. Relaxation \_\_\_\_ helps us to refresh ourselves, even after a tiresome work.



4. Study the given pie chart and write a paragraph of 50 words.

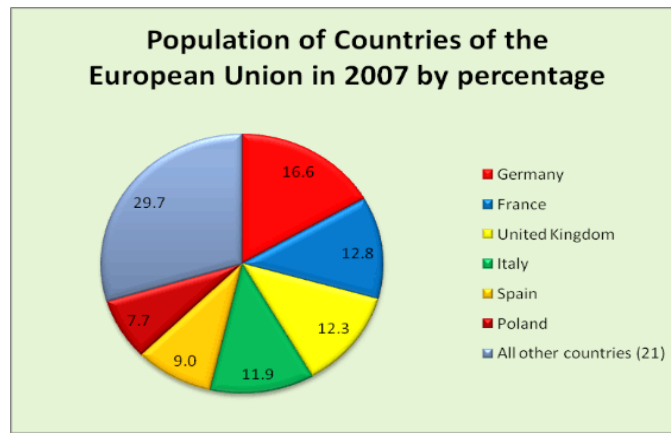

5. Develop the following hints into a passage of about 50 words.

Madurai—city of temples—famous for Meenakshi temple—tourist spots—NayakarMahal, AlagarKoil, Tiruparankundram—lots of hotels of various categories—ordinary to 5 star hotels—parks, playgrounds, gyms, swimming pools, theatres, shops, malls—bus-stands, railway stations, airport

\*\*\*

**\*\* Note: Guide line for setting the question paper is given in the Annexure - I**

## **Annexure – I**

### **Guidelines for setting question paper Semester – I**

**Vocabulary based questions like (Q 1.1, 1.2, 1.3, and 1.12) may be taken from the textbook.**

**Q 1.1 & 1.2 odd words - short & long words**

- ❖ Mono and disyllabic common words used in day to day life should be given for identifying the phonetically odd word

**Q 2.7 Road Map**

- ❖ The question should have instruction 'Give three directions using imperative form'

**Q 3.1 comprehension**

- ❖ Questions should precede the paragraph

**Q 4.4 verbal to visual**

- ❖ Paragraphs should be selected in such a way that they lend themselves to converting into graphics / flow chart / bar chart / pie chart or table

**Q 4.5 Hints development**

- ❖ Should be about popular places, festivals & well known Simple stories

\*\*\*

## ANNEXURE

### STATE BOARD OF TECHNICAL EDUCATION & TRAINING, TAMILNADU DIPLOMA IN ENGINEERING / TECHNOLOGY SYLLABUS M-SCHEME

(Implements from the Academic year 2015-2016 onwards)

Course Name : All branches of Diploma in Engineering and Technology and Special Programmes except DMOP, HMCT and film & TV.

Subject Code : 30012

Semester : I Semester

Subject Title : **ENGINEERING MATHEMATICS – I**

#### TRAINING AND SCHEME OF EXAMINATION:

No. of Weeks per Semester: 15 Weeks

Subject	Instructions		Examination			Duration
	Hours / Week	Hours / Semester	Marks			
Engineering Mathematics - I	8 Hrs.	120 Hrs.	Internal Assessment	Semester Examination	Total	3 Hrs
			25	75	100	

#### TOPICS AND ALLOCATION OF HOURS:

Sl.No.	Topics	Time (Hrs.)
1	Algebra – Determinants, Matrices and Binomial Theorem	22
2	Complex Numbers	22
3	Trigonometry	22
4	Inverse Trigonometric Ratios & Differential Calculus - I	22
5	Differential Calculus – II	22
Test and Tutorial		10
<b>TOTAL</b>		<b>120</b>

#### **Rationale:**

This subject being a branch of “Logic” is classified as one of the basic sciences and intends to teach students, basic facts, concepts and principles of mathematics as a tool to analyse Engineering problems. Mathematics lay down foundation for understanding core technology subjects.

**Objectives:**

This subject helps the students to develop logical thinking which is useful in Comprehending the principles of all other subjects. Analytical and systematic approach towards any problem is developed through learning of this subject. Mathematics being a versatile subject can be used at every stage of human life. The student will be able to acquire knowledge of algebra of complex numbers and its uses to solve equations having non-real solutions and knowledge of differentiation, principles and different methods, develop the ability to apply these methods to solve technical problems to execute management plans with precision.

**30012 ENGINEERING MATHEMATICS - I**  
**DETAILED SYLLABUS**

**Contents: Theory**

UNIT	NAME OF TOPICS	Hours
<b>I</b>	<b>ALGEBRA</b>	
	<b>Chapter - 1.1 DETERMINANTS</b> Definition and expansion of determinants of order 2 and 3. Properties of determinants (not for examination). Solution of simultaneous equations using Cramer's rule (in 2 and 3 unknowns) - Simple Problems.	<b>7</b>
	<b>Chapter - 1.2 MATRICES</b> Definition –Singular Matrix, Non-singular Matrix, Adjoint of a matrix and Inverse of a matrix up to 3 x 3 only. Simple Problems. Definition – Rank of a matrix. Finding rank of a matrix by determinant method (matrix of order 3 x 4) Simple Problems.	<b>7</b>
	<b>Chapter - 1.3 BINOMIAL THEOREM</b> Definition of Factorial notation - Definition of Permutation and Combinations – values of $nP_r$ and $nC_r$ (results only) [not for examination]. Binomial theorem for positive integral index (statement only) - Expansion - Finding of general term, middle term, coefficient of $x^n$ and term independent of $x$ . Simple Problems. Binomial Theorem for rational index up to - 3 (statement only), Expansions only for - 1, - 2 and - 3.	<b>8</b>

II	<b>COMPLEX NUMBERS</b>		
	<b>Chapter - 2.1 ALGEBRA OF COMPLEX NUMBERS</b> Definition – Real and Imaginary parts, Conjugates, Modulus and amplitude form, Polar form of a complex number, multiplication and division of complex numbers (geometrical proof not needed)– Simple Problems .Argand Diagram – Collinear points, four points forming square, rectangle, rhombus and parallelogram only . Simple Problems.		<b>8</b>
	<b>Chapter - 2.2 DE MOIVER’S THEOREM</b> Demoiivre’s Theorem (statement only) – related simple problems.		<b>7</b>
	<b>Chapter - 2.3 ROOTS OF COMPLEX NUMBERS</b> Finding the $n^{th}$ roots of unity - solving equation of the form $x^n \pm 1 = 0$ where $n \leq 7$ . Simple Problems.	<b>7</b>	
III	<b>TRIGONOMETRY</b>		
	<b>Chapter – 3.1 COMPOUND ANGLES</b> Expansion of $\sin(A \pm B)$ , $\cos(A \pm B)$ and $\tan(A \pm B)$ [without proof] . Problems using above expansions.		<b>8</b>
	<b>Chapter - 3.2 MULTIPLE ANGLES</b> Trigonometrical ratios of multiple angles of $2A$ and $3A$ and sub multiple angles. Simple Problems.		<b>7</b>
	<b>Chapter - 3.3 SUM AND PRODUCT FORMULAE</b> Trigonometrical ratios of sum and product formulae. Simple Problems.	<b>7</b>	
IV	<b>INVERSE TRIGONOMETRIC RATIOS &amp; DIFFERENTIAL CALCULUS – I</b>		
	<b>Chapter - 4.1 INVERSE TRIGONOMETRIC FUNCTIONS</b> Definition of inverse trigonometric ratios – Relation between inverse trigonometric ratios. Simple Problems.		<b>7</b>
	<b>Chapter - 4.2 LIMITS</b> Definition of Limits. Problems using the following results: $(i) \lim_{x \rightarrow a} \frac{x^n - a^n}{x - a} = na^{n-1} \quad (ii) \lim_{\theta \rightarrow 0} \frac{\sin \theta}{\theta} = 1 \quad \text{and}$ $(iii) \lim_{\theta \rightarrow 0} \frac{\tan \theta}{\theta} = 1 \quad (\theta - \text{in radians}) \text{ (results only) . Simple Problems.}$		<b>7</b>
	<b>Chapter - 4.3 DIFFERENTIATION</b> Definition – Differentiation of $x^n$ , $\sin x$ , $\cos x$ , $\tan x$ , $\operatorname{cosec} x$ , $\sec x$ , $\cot x$ , $\log x$ , $e^x$ , $u \pm v$ , $uv$ , $uvw$ , $\frac{u}{v}$ ( $v \neq 0$ ) (results only). Simple problems using the above results.	<b>8</b>	

<b>V</b>	<b>DIFFERENTIAL CALCULUS – II</b>	
	<b>Chapter – 5.1 DIFFERENTIATION METHODS</b> Differentiation of function functions (chain rule), Inverse Trigonometric functions and Implicit functions. Simple Problems.	<b>8</b>
	<b>Chapter - 5.2 SUCCESSIVE DIFFERENTIATION</b> Successive differentiation up to second order (parametric form not included). Definition of differential equation, order and degree, formation of differential equation. Simple Problems.	<b>7</b>
	<b>Chapter - 5.3 PARTIAL DIFFERENTIATION</b> Definition – Partial differentiation of two variables up to second order only. Simple Problems.	<b>7</b>

**Text Book:**

1. Mathematics for Higher Secondary – I year and II year (Tamil Nadu Text Book Corporation)

**Reference Book:**

1. Engineering Mathematics - Dr.M.K.Venkatraman, National Publishing Co, Chennai
2. Engineering Mathematics – Dr.P.Kandasamy & Others, S.Chand & Co Ltd, New Delhi

## Board Examination - Question paper pattern

Time: 3 Hrs.

Max.Marks: 75

**PART A** - 5 Questions to be answered out of 8 for 2 marks each.

**PART B** - 5 Questions to be answered out of 8 for 3 marks each.

**PART C** - All the 5 Questions to be answered

Each question in PART C will contain 3 Sub questions, out of these 3 Sub questions 2 Sub questions is to be answered for 5 marks each.

<b>PART A</b>	5 x 2 marks	10 Marks
<b>PART B</b> Short answer type questions	5 x 3 marks	15 Marks
<b>PART C</b> Descriptive answer type questions Each question in PART C will contain 3 Sub questions, out of these 3 Sub questions 2 Sub questions is to be answered for 5 marks each.	5 x 2 x 5 marks	50 Marks
Total		75 Marks

Out of the 3 Sub questions in PART C, one sub question must be on problem based to test the analytical ability/logical ability /diagnostic ability/conceptual ability relevant to that subject content. Equal weightage is to be given to whole syllabus.

Clarks table will not be permitted for the Board Examinations.

## ANNEXURE

### STATE BOARD OF TECHNICAL EDUCATION & TRAINING, TAMILNADU DIPLOMA IN ENGINEERING / TECHNOLOGY SYLLABUS M-SCHEME

(Implements from the Academic year 2015-2016 onwards)

Course Name : All branches of Diploma in Engineering and Technology and Special Programmes except DMOP, HMCT and film & TV.

Subject Code : 30013

Semester : I Semester

Subject Title : **ENGINEERING PHYSICS –I**

#### TEACHING AND SCHEME OF EXAMINATION:

No of weeks per semester: 15 weeks

Subject	Instructions		Examination			Duration
	Hours / Week	Hours / Semester	Marks			
			Internal Assessment	Board Examination	Total	
ENGINEERING PHYSICS I	5 Hrs	75Hrs	25	75	100	3Hrs

#### Topics and Allocation of Hours:

Sl.No	Topic	Time(Hrs)
1	S I UNITS AND STATICS	13 Hours
2	PROPERTIES OF MATTER	13 Hours
3	DYNAMICS- I	13 Hours
4	DYNAMICS–II	13 Hours
5	SOUND AND MAGNETISM	13 Hours
	REVISION + TEST + MODEL EXAM	10 Hours
	<b>Total</b>	<b>75 Hours</b>



## **RATIONALE:**

The exponential growth of Engineering and Technology has benefited the mankind with extreme sophistication and comfort. To sustain this development, continuous research and development should take place not only in Engineering and Technology but also in Basic Science such as Physics.

The various divisions of Physics like Statics, Dynamics, Elasticity, Rotational Motion, Sound, Magnetism etc provide the Foundation by enlightening the Fundamental facts, Principles, Laws and Correct sequence of events to develop the Engineering and Technology field for the prosperity of human beings.

## **OBJECTIVES:**

At the end of the study of I Semester the student will be able to

- Understand the importance of SI units and dimensional formulae.
- Acquire broad ideas about resultant, moment of a force and torque of a couple.
- Understand the elastic property and the types of Modulus of elasticity.
- Explain the surface tension of liquids and viscosity of fluids.
- Understand Newton's laws of motion and equations of different types of motion.
- Acquire knowledge about projectile motion, circular motion and its application.
- Understand the concepts of simple harmonic motion
- Gain knowledge about rotational kinetic energy and angular momentum.
- Acquire broader ideas about variation of acceleration with respect to height and its importance in launching satellites.
- Understand the propagation of sound and acoustics of buildings.
- Explain the importance of hysteresis of magnetic materials and its uses.
- Solve simple problems involving expressions derived in all the above topics.

## 30013 ENGINEERING PHYSICS – I

### DETAILED SYLLABUS

#### Contents: Theory

Unit	Name of the Topic	Hours
I	<b>SI UNITS AND STATICS</b> <b><u>1.1 UNITS AND MEASUREMENTS:-</u></b> Unit-Definition-Fundamental Quantities-Definition-Seven fundamental quantities; their SI units and symbol for the units- Supplementary quantities-plane angle and solid angle; their SI units and symbol for the units Derived physical quantities. Dimensional formula for length, mass and time-derivation of dimensional formula for area, volume, density, velocity, momentum, acceleration, force, impulse, work or energy and power. Uses of Dimensional formula. Conventions followed in SI –Units Multiples & sub-multiples and prefixes of units.	4Hrs
	<b><u>1.2 STATICS:-</u></b> Scalar and vector quantities–Definitions and examples–Concurrent forces and coplanar forces–Definition-Resolution of a vector into two perpendicular components-Resultant and equilibrant–Definitions-Parallelogram law of forces-statement-Expressions for magnitude and direction of the resultant of two forces acting at a point with an acute angle between them-Lami’s theorem-Statement and explanation-Experimental verification of parallelogram law of forces and Lami’s theorem. Simple problems based on expressions for magnitude and direction of resultant. Moment of a force-Clockwise and anti-clockwise moments-Principle of moments-Couple–Torque acting due to a Couple–Experimental determination of mass of the given body using principle of moments.	9 Hrs
II	<b>PROPERTIES OF MATTER</b> <b><u>2.1 ELASTICITY:-</u></b> Elastic and plastic bodies–Definition-stress, strain-Definitions–Hooke’s law – statement-three types of strain–Elastic and plastic limit–Young’s modulus, Bulkmodulus, Rigidity modulus and Poisson’s ratio–Definitions-Uniform and non-uniform bending of beams-Experimental determination of the Young’s modulus of the material of a beam by uniform bending method. Simple problems based on stress, strain and Young’s modulus.	4 Hrs
	<b><u>2.2 VISCOSITY:-</u></b> Viscosity–Definition-Coefficient of viscosity-Definition, Slunit and dimensional formula-Stream line flow, turbulent flow-Explanation-Critical velocity–Definition-Reynolds number-Experimental comparison of coefficient of viscosity of two low viscous liquids–Terminal velocity–Definition-Experimental determination of coefficient of viscosity of a highly viscous liquid by Stokes method–Practical applications of viscosity.	5Hrs

	<p><b><u>2.3 SURFACE TENSION:-</u></b>  Surface tension &amp; angle of contact-Definitions-Expression for surface tension of a liquid by capillary rise method-Experimental determination of surface tension of water by capillary rise method-Practical applications of capillarity. Simple problems based on expression for surface tension.</p>	4Hrs
III	<p><b>DYNAMICS-I</b></p>	
	<p><b><u>3.1.STRAIGHTLINE MOTION:-</u></b>  Introduction-Newton's Laws of motion-Fundamental Equations of motion for objects- horizontal motion-falling freely-thrown vertically upwards.</p>	2 Hrs.
	<p><b><u>3.2 PROJECTILE MOTION:-</u></b>  Projectile motion, angle of projection, trajectory, maximum height, time of flight, and horizontal range-Definitions-Expressions for maximum height, time of flight and horizontal range-Condition for getting the maximum range of the projectile-Derivation of the equation to show that the trajectory of the projectile is a parabola.Simple problems based on expressions for maximum height, time of flight and horizontal range.</p>	4Hrs.
	<p><b><u>3.3 CIRCULAR MOTION:-</u></b>  Circular motion, angular velocity, period and frequency of revolutions-Definitions-Relation between linear velocity and angular velocity-Relation between angular velocity, period and frequency-Normal acceleration, centripetal force and centrifugal force-Definitions-Expressions for normal acceleration and centripetal force. Banking of curved paths-Angle of banking-Definition-Expression for the angle of banking of a curved path. <math>\{ \tan\theta = \frac{v^2}{r g} \}</math>Simple problems based on the expressions for centripetal force and angle of banking.Simple harmonic motion, amplitude, frequency and period-Definitions.</p>	7Hrs.
IV	<p><b>DYNAMICS-II</b></p>	
	<p><b><u>4.1 ROTATIONAL MOTION OF RIGID BODIES:-</u></b>  Rigid body-Definition-Moment of inertia of a particle about an axis, moment of inertia of a rigid body about an axis-expressions-Radius of gyration-Definition-Expression for the kinetic energy of a rotating rigid body about an axis-Angular momentum-Definition-Expression for the angular momentum of a rotating rigid body about an axis-Law of conservation of angular momentum-Examples.</p>	6Hrs
	<p><b><u>4.2 GRAVITATION:-</u></b>  Newton's laws of gravitation-Acceleration due to gravity on the surface of earth-Expression for variation of acceleration due to gravity with altitude</p>	3Hrs
	<p><b><u>4.3 SATELLITES:-</u></b>  Satellites-Natural and artificial-Escape velocity and orbital velocity-Definitions-Expression for escape velocity-Expression for orbital velocity -Uses of artificial satellites. Simple problems based on the expressions for escape velocity and orbital velocity.</p>	4Hrs
V	<p><b>SOUND AND MAGNETISM</b></p>	
	<p><b><u>5.1 SOUND:-</u></b>  Wave motion-Introduction and definition-Audible range-Infrasonic-Ultrasonics-Progressive waves, longitudinal and transverse waves-Examples- Amplitude, wave length, period and frequency of a wave-Definitions-Relation between</p>	8Hrs

<p>wave length, frequency and velocity of a wave-Stationary or standing waves. Vibrations-Free &amp; forced vibrations and resonance-definitions and examples-Laws of transverse vibrations of a stretched string-Sonometer-Experimental determination of frequency of a tuning fork.Acoustics of buildings-Echo-Reverberation, reverberation time, Sabine's formula for reverberation time (no derivation) -Coefficient of absorption of sound energy-Noise pollution.Simple problems based on expression for frequency of vibration.</p> <p><b><u>5.2 MAGNETISM:-</u></b>  Pole strength -Definitions-Magnetic moment, intensity of magnetisation, magnetising field intensity, magnetic induction, permeability, hysteresis, saturation, retentivity and coercivity - Definitions - Method of drawing hysteresis loop of a specimen using a solenoid-Uses of Hysteresis loop simple problem based on intensity of magnetization.</p>	5Hrs
---	------

Text Book:

1. Published by DOTE-Govt of Tamil Nadu
2. Physics-Higher secondary-First year-Volume I & II TamilNaduTextbook Corporation 2004

Reference Book :

1. Physics-Resnick and Haliday-Wisley Toppan publishers-England
2. Engineering Physics-B.L.Theraja-S. Chand Publishers
3. A text book of sound-R.L. Saighal & H.R. Sarna-S.Chand & Co.
4. Mechanics-Narayana Kurup-S. Chand Publishers.

## Board Examination - Question paper pattern

Time: 3 Hrs.

Max.Marks: 75

**PART A** - 5 Questions to be answered out of 8 for 2 marks each.

**PART B** - 5 Questions to be answered out of 8 for 3 marks each.

**PART C** - All the 5 Questions to be answered

Each question in PART C will contain 3 Sub questions, out of these 3 Sub questions 2 Sub questions is to be answered for 5 marks each.

<b>PART A</b>	5 x 2 marks	10 Marks
<b>PART B</b> Short answer type questions	5 x 3 marks	15 Marks
<b>PART C</b> Descriptive answer type questions Each question in PART C will contain 3 Sub questions, out of these 3 Sub questions 2 Sub questions is to be answered for 5 marks each.	5 x 2 x 5 marks	50 Marks
Total		75 Marks

Out of the 3 Sub questions in PART C, one sub question must be on problem based to test the analytical ability/logical ability /diagnostic ability/conceptual ability relevant to that subject content. Equal weightage is to be given to whole syllabus.

Clarks table will not be permitted for the Board Examinations.

## ANNEXURE

### STATE BOARD OF TECHNICAL EDUCATION & TRAINING, TAMILNADU DIPLOMA IN ENGINEERING / TECHNOLOGY SYLLABUS M-SCHEME

(Implements from the Academic year 2015-2016 onwards)

Course Name : All branches of Diploma in Engineering and Technology and Special Programmes except DMOP, HMCT and film & TV.

Subject Code : 30014

Semester : I Semester

Subject Title : **ENGINEERING CHEMISTRY – I**

#### TEACHING AND SCHEME OF EXAMINATION:

No. of Weeks per Semester: 15 Weeks

Subject	Instructions		Examination			Duration
	Hours / Week	Hours / Semester	Marks			
			Internal Assessment	Board Examination	Total	
ENGINEERING CHEMISTRY - I	5	75	25	75	100	3 Hrs

#### **Topics and Allocation of Hours:**

Sl. No	Topics	Time (Hrs)
1	Atomic Structure, Molecular Mass, Acids and Bases	13 Hours
2	Solutions, Colloids, Nano-Particles	13 Hours
3	Technology of Water, Catalysis, Glass	13 Hours
4	Electrochemistry, Electrochemical Cell, Energy Sources	13 Hours
5	Corrosion, Methods of Prevention of Corrosion, Organic Coatings	13 Hours
	Revision and Examinations	10 Hours
<b>Total</b>		<b>75 Hours</b>

#### **RATIONALE:**

The subject Engineering Chemistry creates foundation for understanding basic concepts of chemistry and its effects on Engineering Materials. Engineering Chemistry also impart knowledge of properties of materials and protecting them from corrosion and selecting right types of materials used in various fields of Engineering and Industry.

#### **OBJECTIVES:**

The objective of this Course is to make the student:

1. Study about the importance of Engineering Chemistry in industry.
2. Know about atomic structure, molecular mass and acids and bases.
3. Learn about solutions, colloidal particles and nano-particles.
4. Know about hardness of water, catalysis and glass.
5. Explain the details of electrochemistry, electrochemical cell and energy sources.
6. Understand corrosion and its prevention methods.

**30014 ENGINEERING CHEMISTRY – I****DETAILED SYLLABUS****Contents: Theory**

<b>Unit</b>	<b>Name of the Topic</b>	<b>Hours</b>
<b>I</b>	<b>ATOMIC STRUCTURE, MOLECULAR MASS, ACIDS AND BASES</b>	
	<b>1.1 Atomic Structure</b> Atom – Definition – Fundamental particles of Atom – their Mass, Charge and Location – Atomic number and Mass number – Definition – Isotopes and Isobars – Definition with suitable examples – Formation of cation and anion by electronic concept of oxidation and reduction – Octet rule – Formation of electrovalent compound (NaCl) – Formation of covalent compound (NH <sub>3</sub> ).	<b>4 Hrs</b>
	<b>1.2 Molecular Mass</b> Molecule – Molecular Formula – Molecular Mass – Mole – Definition – Simple calculations – Avogadro's Hypothesis – Relationship between Molecular Mass and Vapour Density – Avogadro Number – Definition.	<b>4 Hrs</b>
	<b>1.3 Acids and Bases</b> Theories of Acids and Bases – Arrhenius Theory – Lowry – Bronsted Theory – Lewis Theory – Advantages of Lewis Theory – pH and pOH – Definition – Numerical problems – Indicator – Definition and Examples only – Buffer solution – Definition – Types of buffer solution with examples – Application of pH in Industries.	<b>5 Hrs</b>
<b>II</b>	<b>SOLUTIONS, COLLOIDS, NANO-PARTICLES</b>	
	<b>2.1 Solutions</b> Definition – Methods of expressing concentration of a solution – Molarity, Molality, Normality, Mole fraction and Percentage Mass – Simple problems.	<b>4 Hrs</b>
	<b>2.2 Colloids</b> True solution and Colloidal solution – Definition – Differences – Types of colloids – Lyophilic and Lyophobic colloids – Differences – Properties – Tyndall effect, Brownian movement, Electrophoresis and Coagulation – Industrial applications of colloids – Smoke Precipitation by Cottrell's method, Purification of water, Cleansing action of soap, Tanning of leather and Sewage disposal.	<b>6 Hrs</b>
	<b>2.3 Nano-Particles</b> Definition – Importance of Nano-particles – Area of application – Medicine, Electronics and Biomaterials.	<b>3Hrs</b>

Unit	Name of the Topic	Hours
III	<p data-bbox="354 218 1029 247"><b>TECHNOLOGY OF WATER, CATALYSIS, GLASS</b></p> <p data-bbox="354 289 699 319"><b>3.1 Technology of Water</b></p> <p data-bbox="354 323 1325 695">Sources of water – Reasons for depletion of underground water – Rain water harvesting (Basic ideas) – Advantages – Hard water and soft water – Hardness of water – Carbonate and Non-carbonate hardness – Methods of expressing hardness – mg/lit and ppm – Simple problems – Estimation of total hardness of water by EDTA method – Problems involving Total, Carbonate and Non-carbonate hardness in ppm – Softening of hard water – Ion-Exchange method and Reverse Osmosis method – Municipal water supply – Purification (Sedimentation, Filtration and Sterilization) – Disadvantages of using hard water in boilers – Scale formation, Corrosion of boiler metal, Caustic Embrittlement and Priming and Foaming.</p> <p data-bbox="354 716 537 745"><b>3.2 Catalysis</b></p> <p data-bbox="354 762 1325 894">Catalyst – Positive catalyst – Negative catalyst – Definition – Types of catalysis – Homogeneous and Heterogeneous – Promoter – Catalyst poison – Definition – Characteristics of a catalyst – Industrial applications of catalysts.</p> <p data-bbox="354 915 488 945"><b>3.3 Glass</b></p> <p data-bbox="354 961 1325 1024">Definition – Manufacture of Glass – Varieties of Glass – Optical Glass, Windshield Glass and Photo chromatic Glass.</p>	<p data-bbox="1344 289 1425 319">6 Hrs</p> <p data-bbox="1344 730 1425 760">4 Hrs</p> <p data-bbox="1344 905 1425 934">3 Hrs</p>
IV	<p data-bbox="354 1079 1208 1142"><b>ELECTROCHEMISTRY, ELECTROCHEMICAL CELL, ENERGY SOURCES</b></p> <p data-bbox="354 1184 646 1213"><b>4.1 Electrochemistry</b></p> <p data-bbox="354 1230 1325 1434">Electrolyte – Definition – Strong and Weak electrolytes – Examples – Electrolysis – Definition – Mechanism – Industrial application of Electrolysis – Electroplating – Preparation of surface – Process – Factors affecting the stability of the coating – Chrome plating – Electroless plating – Definition – Advantages of Electroless plating over electroplating – Applications of Electroless plating.</p> <p data-bbox="354 1455 695 1484"><b>4.2 Electrochemical Cell</b></p> <p data-bbox="354 1501 1325 1633">Electrochemical Cell – Definition – Representation of a Cell – Single Electrode Potential – Definition – Galvanic Cell – Formation of Daniel Cell – Electrochemical Series – Definition and Significance – Electrolytic Concentration Cell – Definition and Formation.</p> <p data-bbox="354 1654 630 1684"><b>4.3 Energy Sources</b></p> <p data-bbox="354 1701 1325 1864">Primary Battery – Definition and example – Construction, Working and Uses of Dry cell – Secondary Battery – Definition and example – Construction, Working and Uses of Lead-acid Storage Cell – Non-conventional Energy Sources – Solar Cell – Definition – Principle, Construction, Working and Uses.</p>	<p data-bbox="1344 1184 1425 1213">5 Hrs</p> <p data-bbox="1344 1457 1425 1486">4 Hrs</p> <p data-bbox="1344 1661 1425 1690">4 Hrs</p>



Unit	Name of the Topic	Hours
V	<b>CORROSION, METHODS OF PREVENTION OF CORROSION, ORGANIC COATINGS</b>	
	<b>5.1 Corrosion</b> Definition – Types of Corrosion – Theories of corrosion – Galvanic Cell Formation Theory – Differential Aeration theory – Factors influencing the rate of corrosion.	<b>4 Hrs</b>
	<b>5.2 Methods of Prevention of Corrosion</b> Control of Environment – Alloying – Surface coatings – Metal coatings – Electroplating, Galvanization and Tinning – Inorganic coating – Anodizing – Cathodic Protection – Sacrificial Anode Method and Impressed Voltage Method.	<b>4 Hrs</b>
	<b>5.3 Organic Coatings</b> Paint – Definition – Components of Paints and their functions – Varnish – Definition – Preparation of Oil Varnish – Differences between Paint and Varnish – Special Paints – Luminescent Paints, Fire Retardant Paints, Aluminium Paints and Distemper.	<b>5 Hrs</b>

**Text Book:**

1. Engineering Chemistry – I Tamil Nadu Text Book Corporation
2. Engineering Chemistry – Jain & Jain – Dhanpat Rai & Sons.
3. A Text Book of Engineering Chemistry – S.S. Dara – S. Chand Publication.

**Reference Book:**

1. A Text Book of Environmental Chemistry and Pollution Control S.S. Dara – S. Chand Publication.
2. Engineering Chemistry – Uppal – Khanna Publishers.
3. Chemistry – Higher Secondary – Second Year – Volume I & II – Tamil Nadu Text Book Corporation – 2014.
4. Environmental Chemistry – V P Kudesia – Pragati Publishers.

## Board Examination - Question paper pattern

**Time: 3 Hrs.**

**Max.Marks: 75**

**PART A** - 5 Questions to be answered out of **8** for 2 marks each.

**PART B** - 5 Questions to be answered out of **8** for 3 marks each.

**PART C** - All the **5** Questions to be answered

Each question in PART C will contain **3** Sub questions, out of these **3** Sub questions **2** Sub questions is to be answered for 5 marks each.

<b>PART A</b>	<b>5 x 2 marks</b>	<b>10 Marks</b>
<b>PART B</b> Short answer type questions	<b>5 x 3 marks</b>	<b>15 Marks</b>
<b>PART C</b> Descriptive answer type questions  Each question in PART C will contain <b>3</b> Sub questions, out of these <b>3</b> Sub questions <b>2</b> Sub questions is to be answered for 5 marks each.	<b>5 x 2 x 5 marks</b>	<b>50 Marks</b>
Total		<b>75 Marks</b>

Out of the **3 Sub questions** in **PART C**, **one sub question** must be on problem based to test the analytical ability/logical ability /diagnostic ability/conceptual ability relevant to that subject content. Equal weightage is to be given to whole syllabus.

Clarks table will not be permitted for the Board Examinations.

## ANNEXURE

**STATE BOARD OF TECHNICAL EDUCATION & TRAINING, TAMILNADU  
DIPLOMA IN ENGINEERING / TECHNOLOGY SYLLABUS  
M-SCHEME  
(Implements from the Academic year 2015-2016 onwards)**

Course Name : All branches of Diploma in Engineering and Technology and Special Programmes except DMOP, HMCT and film & TV.

Subject Code : 30015

Semester : I Semester

Subject Title : **ENGINEERING GRAPHICS – I**

### TEACHING AND SCHEME OF EXAMINATION

**No. of weeks per semester: 15 weeks**

Subject	Instructions		Examination			Duration
	Hours / Week	Hours / Semester	Marks			
ENGINEERING GRAPHICS - I	5	75	Internal Assessment	Board Examination	Total	3 Hrs.
			25	75	100	

### **Topics and Allocation of Hours**

Sl.No.	Topics	Time (Hrs)
1	Drawing office practice, Lettering and Dimensions.	15 Hrs.
2	Geometric Constructions and Constructions of conics curve	20 Hrs.
3	Projection of points and straight lines.	17 Hrs
4	Orthographic projections.	23 Hrs.
	<b>Total</b>	<b>75 Hrs.</b>

### **RATIONALE:**

Engineering graphics is a basic subject for all branches of Diploma Engineering and Technology. Since engineering drawing is considered as the language of engineers, the proper understanding and practice is required with proper instruments.

This subject is aimed at providing basic understanding of the fundamentals of Engineering Drawing; mainly visualization, graphics theory, standards & conventions of drawing, the tools of drawing and the use of Drawings in engineering applications.

The topics covered are based on the syllabus for Diploma studies in engineering. The subject is planned to include sufficient practices which would help the student in visualization of three dimensional objects and developing the drawing.

The chapters are arranged in sequence and starts from the basic concepts of geometrical constructions & engineering curves, proceeds to the principles of projection techniques. By the end of the subject it is expected that the students would be matured to visualize any engineering component by reading an engineering drawing.

**OBJECTIVES:**

At the end of the practice, the students will be able to,

- Understand the importance of drawing.
- Identify and use the drawing instruments.
- Practice the rules and methods of dimensioning.
- Acquire knowledge about geometric construction.
- Construct conics curves.
- Draw the projection of points and straight lines.
- Draw orthographic views from isometric drawings.

**30015 ENGINEERING GRAPHICS – I**

**DETAILED SYLLABUS**

**Contents: Theory**

Unit	Name of the Topic	Hours
I	<p><b>1. 1. Drawing office practice</b>            Importance of engineering drawing - drawing instruments: drawing board, mini drafter, compass, divider, protractor, drawing sheets, drawing pencils, set squares etc.,-title block – folding of drawing sheets.            Lettering and numbering as per BIS 9609 - importance - single stroke letters – slanting letters - upper case and lower case letters - general procedures for lettering and numbering - height of letters – guidelines-practices.            Scales - full scale, reduced scale and enlarged scale.</p> <p><b>1. 2. Dimensioning</b>            Dimensioning – terms and notations as per BIS -requirement of dimensioning - Dimension line, Extension lines and Leader lines – Dimensioning systems - Methods of dimensioning – Important dimensioning rules – Exercises (One view of the object).</p>	15
II	<p><b>2.1 Geometric Constructions</b>            Geometric constructions: Bisect a line – bisect an arc – bisect given angle – divide straight line into number of equal parts – divide the circle into number of equal divisions – draw an arc touching two lines at any angle – draw an arc touching two arcs.</p>	20

	<p><b>2.2 Constructions of conics</b></p> <p>Conics: Cone – conic sections - Definition of locus, focus, directrix, axis, vertex and eccentricity. Definition: ellipse, parabola and hyperbola.</p> <p>Ellipse: Construction of ellipse by concentric circle method, rectangular method and Eccentricity method when focus and directrix are given – Exercises.</p> <p>Parabola: Construction of parabola by rectangular method, parallelogram method and eccentricity method when focus and directrix are given– exercises.</p> <p>Hyperbola: Construction of hyperbola by rectangular method and eccentricity method when focus and directrix are given – exercises.</p>	
III	<p><b>3.1 Projection of points.</b></p> <p>Projection of points – points on the different quadrants and on the reference planes.</p> <p><b>3.2 Projection of straight lines.</b></p> <p>Projection of straight lines – Line in the first quadrant and on the reference planes - perpendicular to one plane and parallel to other plane – inclined to one plane and parallel to the other plane – parallel to both the planes – inclined to both the planes – Exercises.</p>	17
IV	<p><b>4.1. Orthographic projection</b></p> <p>Introduction – Orthographic projection - terms - First angle projection - Third angle projection – Draw symbols – Compare first and third angle projections.</p> <p>Draw the projection of the simple isometric objects using first angle projection only – Draw front view / top view / right / left side view.(Any two views only)</p>	23

### Text Books

1. Bhatt N.D. and Panchal V.M., “Engineering Drawing”, Charotar Publishing House, 50<sup>th</sup> Edition, 2010.
2. Gill P.S., “Engineering drawing”, S.K.Kataria & Sons.

### Reference Books

1. Gopalakrishnan.K.R., "Engineering Drawing", (Vol.I and Vol.II), Dhanalakshmi publishers, Edition 2, 1970
2. Venugopal.K, Sreekanjana G, “Engineering Graphics” New Age International Publishers.
3. K V Nataraajan “A Text Book of Engineering Drawing”
4. Besant Agrawal, C M Agrawal “Engineering drawing”, Tata McGraw Hill Education Private Limited.
5. Barkinson & Sinha, "First Year Engineering Drawing", Pitman Publishers.

## Board Examination – Question pattern

**Time: 3 Hrs.**

**Max.Marks: 75**

[Note: Answer all the questions in the drawing sheet only. Assume missing dimensions suitably]

### **Part A**

Answer all questions. Each question carries five marks.

3 X 5 = 15

**Note: Three questions will be asked (1 to 3). One question from UNIT I, II and III.  
(Lettering, Geometric constructions and Projection of Points.)**

### **Part B**

Answer any four questions. Each question carries fifteen marks.

4 X 15 = 60

**Note: Six questions will be asked (4 to 9). Minimum one question from each unit.**

**TOTAL                      75**

### **Internal Marks**

Assignment drawings	-	10
Test	-	10
Attendance	-	5
<b>Total</b>	<b>-</b>	<b>25</b>

## ANNEXURE

### STATE BOARD OF TECHNICAL EDUCATION & TRAINING, TAMILNADU DIPLOMA IN ENGINEERING / TECHNOLOGY SYLLABUS M-SCHEME

(Implements from the Academic year 2015-2016 onwards)

Course Name: All Branches of Diploma in Engineering and Technology and Special Programmes except DMOP, HMCT and Film & TV

Subject Code: **30016**

Semester : I Semester

Subject Title: **ENGINEERING PHYSICS - I PRACTICAL**

#### TEACHING AND SCHEME OF EXAMINATION:

**No. of Weeks per Semester: 15 Weeks**

Subject	Instructions		Examination			Duration
	Hours/ Week	Hours/ Semester	Marks			
			Internal Assessment/ Record	Board Examination	Total	
ENGINEERING PHYSICS - I PRACTICAL	2	30	25	75	100	3 Hours

#### RATIONALE:

In Diploma level engineering education skill development plays a vital role. The skill development can be achieved by on hand experience in handling various instruments, apparatus and equipment. This is accomplished by doing engineering related experiments in practical classes in various laboratories.

#### GUIDELINES:

- All the Eight experiments given in the list of experiments should be completed and given for the end semester practical examination.
- In order to develop best skills in handling Instruments / Equipment and taking readings in the practical classes, every two students should be provided with a separate experimental setup for doing experiments in the laboratory.
- The external examiners are requested to ensure that a single experimental question should not be given to more than four students while admitting a batch of 30 students during Board Examinations.

## 30016- ENGINEERING PHYSICS - I PRACTICAL

### LIST OF EXPERIMENTS WITH OBJECTIVES:

#### 1. MICROMETER (SCREW GAUGE).

To measure the thickness of the given irregular glass plate using micrometer. To determine the area of the glass plate using a graph sheet and to calculate the volume of the glass plate.

#### 2. VERNIER CALIPERS.

To measure the length and diameter of the given solid cylinder using vernier calipers and to calculate the volume of the solid cylinder.

#### 3. CONCURRENT FORCES.

To verify the parallelogram law of forces and Lami's theorem.

#### 4. COMPARISON OF VISCOSITIES

To compare the co-efficient of viscosities of two low viscous Liquids by capillary flow method.

#### 5. STOKES' METHOD.

To determine the coefficient of viscosity of a high viscous liquid.

#### 6. SURFACE TENSION.

To determine the surface tension of water by capillary rise method.

#### 7. SONOMETER.

To determine the frequency of the given tuning fork.

#### 8. DEFLECTION MAGNETOMETER

To compare the magnetic moments of the two bar magnets using deflection Magnetometer in Tan A position, by equal distance method .

### ALLOCATION OF MARKS

Formula, Explanation & Diagram	15 marks
Tabulation with proper units	10 marks
Observation (including taking readings)	35 marks
Calculation	10 marks
Result	05 marks
	-----
Total	75 Marks
	-----



## 30016 ENGINEERING PHYSICS – I PRACTICAL

### LIST OF EQUIPMENT

#### 1. MICROMETER (SCREW GAUGE).

Screw gauge, graph sheet and irregular glass plate.

#### 2. VERNIER CALIPERS.

Vernier Calipers and Solid Cylinder

#### 3. CONCURRENT FORCES.

Vertical drawing board, two Z pulleys, three sets of slotted weights (5 x 50g) and twine thread.

#### 4. COMPARISON OF VISCOSITIES

Burette stand, graduated burette without stopper, rubber tube, Capillary Tube, beaker, digital stop watch, two liquids and funnel.

#### 5. STOKES' METHOD.

Stokes' Apparatus, high viscous liquid (Castrol oil), glass beads of Different radii, digital stop watch and screw gauge.

#### 6. SURFACE TENSION.

Beaker with water, capillary tube, iron stand with clamp, pointer, Travelling microscope and hydro static bench.

#### 7. SONOMETER.

Sonometer, screw gauge, tuning fork, rubber hammer, slotted weight hanger set (5 x 0.5kg) and paper rider.  
scale and two bar magnets.

#### 8. DEFLECTION MAGNETOMETER

Deflection Magnetometer, meter scale and two bar magnets

## 30016 ENGINEERING PHYSICS - I PRACTICAL

### MODEL QUESTION PAPER

1. Measure the thickness of the given irregular glass plate using micrometer. Determine the area of the glass plate using a graph sheet and calculate the volume of the glass plate.
2. Measure the length and diameter of the given solid cylinder using Vernier calipers and then calculates the volume of the solid cylinder.
3. Verify the parallelogram law of forces and Lami's theorem using concurrent forces.
4. Compare the coefficient of viscosity of two Liquids by capillary flow method, using graduated burette.
5. Determine the coefficient of viscosity of a high viscous liquid by Stokes' method.
6. Determine the surface tension of water by capillary rise method.
7. Determine the frequency of the given tuning fork using sonometer.
8. Compare the magnetic moments of the two bar magnets using deflection magnetometer in Tan-A position, by equal distance method

=====

## ANNEXURE

### STATE BOARD OF TECHNICAL EDUCATION & TRAINING, TAMILNADU DIPLOMA IN ENGINEERING / TECHNOLOGY SYLLABUS M-SCHEME

(Implements from the Academic year 2015-2016 onwards)

Course Name: All Branches of Diploma in Engineering and Technology and Special Programmes except DMOP, HMCT and Film & TV

Subject Code: **30017**

Semester : I Semester

Subject Title: **ENGINEERING CHEMISTRY – I PRACTICAL**

#### TEACHING AND SCHEME OF INSTRUCTIONS AND EXAMINATION:

No. of Weeks per Semester: 15 Weeks

Subject	Instructions		Examination			Duration
	Hours/ Week	Hours/ Semester	Marks			
			Internal Assessment/ Record	Board Examination	Total	
ENGINEERING CHEMISTRY – I PRACTICAL	2	30	25	75	100	3 Hours

#### OBJECTIVES:

1. At the end of the program the student will have knowledge about volumetric analysis in acidimetric, alkalimetric and permanganometric titration and their applications.
2. To get knowledge of estimation of total hardness, temporary and permanent hardness in the hard water sample.
3. To get knowledge about measurement of pH and to calculate Hydrogen ion concentration in a solution.

#### 30017 ENGINEERING CHEMISTRY – I PRACTICAL

#### CONTENTS

##### Intellectual Skills

1. Carrying out Volumetric titrations and calculation of masses
2. Knowing units for Concentrations of solutions

##### Motor Skills

1. Measure quantities accurately
2. Observe chemical reactions
3. Handle the apparatus carefully

### Acidimetry and Alkalimetry

1. Estimation of weak base (sodium carbonate) using a standard solution of sodium hydroxide and sulphuric acid as link solution. [Test solution should be made up to 100 ml]
2. Estimation of strong base (sodium hydroxide) using a standard solution of sodium carbonate and sulphuric acid as link solution. [Test solution should be made up to 100 ml]
3. Comparison of strengths of two acid solutions using a standard solution of sodium hydroxide
4. Comparison of strengths of two alkaline solutions using a standard solution of oxalic acid

### Permanganometry

5. Estimation of Mohr's salt using a standard solution of ferrous sulphate and potassium permanganate as link solution. [Test solution should be made up to 100 ml]
6. Estimation of Iron in ferrous sulphate solution using a standard solution of ferrous ammonium sulphate and potassium permanganate as link solution. [Test solution should be made up to 100 ml]
7. Comparison of strengths of two potassium permanganate solutions using a standard solution of ferrous sulphate

### Water Analysis

8. Estimation of total hardness of a water sample using EDTA.
9. Determination of pH using a pH meter and calculation of hydrogen ion Concentrations in the solutions (For five given samples). (This question may be given to any two students per batch)

**INTERNAL ASSESSMENT/RECORD : 25 MARKS**  
**BOARD EXAMINATION : 75 MARKS**

### **VOLUMETRIC ANALYSIS:**

FOR	MARKS ALLOTTED
SHORT PROCEDURE	05
VIVA – VOCE	05
TITRATION – I	25
TITRATION – II	25
CALCULATIONS	15
TOTAL	75

### **DETERMINATION OF pH:**

FOR	MARKS ALLOTTED
ANSWER FOR SHORT QUESTIONS ON pH	05
VIVA – VOCE	05
DETERMINATION OF pH	40
CALCULATION OF [H <sup>+</sup> ]	25
TOTAL	75

## MODEL QUESTION PAPER

### MODEL 1:

3 Hours

Estimate the mass of Iron present in whole of the given ferrous sulphate solution using a standard solution of ferrous ammonium sulphate of strength 0.1N and an approximately decinormal solution of potassium permanganate.

### MODEL 2:

3 Hours

Calculate the total hardness of the given sample of water using a standard hard water solution of molarity 0.01M and an approximately decimolar solution of EDTA.

### MODEL 3:

3 Hours

Determine the pH of five given samples using pH meter and calculate the hydrogen ion concentration of the samples. (Any two students per batch).

## SCHEME OF EVALUATION

### VOLUMETRIC ANALYSIS:

FOR	MARKS ALLOTTED
SHORT PROCEDURE	05
VIVA – VOCE	05
TITRATION – I	25
TITRATION – II	25
CALCULATIONS (3 x 5) (Titration - I, Titration - II & Calculations) (For Arithmetic errors 25% Marks may be reduced)	15
TOTAL	75

Titration value accuracy for Titration – I and II:

Accuracy	MARKS
± 0.2 ml	25
above ± 0.2 ml to ± 0.4 ml	21
above ± 0.4 ml to ± 0.6 ml	17
above ± 0.6 ml	5

### DETERMINATION OF pH:

FOR	MARKS ALLOTTED
ANSWER FOR SHORT QUESTIONS ON pH	05
VIVA – VOCE	05
DETERMINATION OF pH (5 SAMPLES) (5 x 8)	40
CALCULATION OF $[H^+]$ (5 x 5)	25
TOTAL	75

pH value Accuracy:

Accuracy	MARKS
± 0.2	8
above ± 0.2 to ± 0.4	6
above ± 0.4	4

**List of Apparatus to be provided for each student in Chemistry Laboratory during the Engineering Chemistry – I Practical Classes/Board Examination in addition to the required Solutions:**

Sl.No.	Name of the Item	Quantity (Nos.)
1	Beaker (100 ml)	1
2	Burette (50 ml)	1
3	Burette Stand	1
4	Conical Flask (250 ml)	1
5	Funnel	1
6	Pipette (20 ml)	1
7	Porcelain Tile	1
8	Standard Flask (100 ml)	1
9	Wash Bottle	1

## FIRST YEAR ENGINEERING CHEMISTRY LABORATORY

### LIST OF EQUIPMENTS

#### LIST OF EQUIPMENTS REQUIRED FOR A BATCH OF 30 STUDENTS

#### NON-CONSUMBALE ITEMS

Sl.No.	Name of the Item	Quantity (Nos.)
1	LPG Connection	
2	Exhaust Fan (High Capacity)	Sufficient Nos.
3	Fire Extinguisher	1
4	First Aid Box (Full Set)	2
5	Safety Chart	1
6	Chemical Balance	1
7	Fractional Weight Box	1
8	pH Meter	5
9	Working Table with all accessories	8

#### GLASSWARE AND OTHER ITEMS

Sl.No.	Name of the Item	Quantity (Nos.)
1	Burette (50 ml)	35
2	Burette Stand	35
3	Pipette (20 ml) (With safety Bulb)	35
4	Pipette (10 ml)	5
5	Conical Flask (250 ml)	35
6	Funnel (3")	50
7	Porcelain Tile	35
8	Measuring Cylinder (10 ml)	5
9	Measuring Cylinder (1000 ml)	2
10	Reagent Bottle (White) (250 ml)	60
11	Reagent Bottle (White) (125 ml)	100
12	Reagent Bottle (Amber) (250 ml)	80
13	Test Tube (15 mm x 1.5 mm)	1000
14	Test Tube (15 mm x 2.5 mm)	500
15	Test Tube Stand	35
16	Test Tube Holder	35
17	Test Tube cleaning brush	35
18	Glass Trough	5
19	Beaker (100 ml)	35
20	Glass Rod (15 cm)	100
21	Watch Glass (3")	35
22	Wash Bottle (Polythene)	35
23	Nickel Spatula	35
24	Bunsen Burner for Gas connection	35
25	Plastic Bucket (15 L)	10
26	Filter Papers (Round)	Sufficient Nos.
27	Standard Flask (100 ml)	35

## ANNEXURE

**STATE BOARD OF TECHNICAL EDUCATION & TRAINING, TAMILNADU**  
**DIPLOMA IN ENGINEERING / TECHNOLOGY SYLLABUS**  
**M-SCHEME**  
**(Implements from the Academic year 2015-2016 onwards)**

Course Name : All branches of Diploma in Engineering and Technology and Special Programmes except DMOP, HMCT and film & TV.

Subject Code : 30018

Semester : I Semester

Subject Title : **WORKSHOP PRACTICE**

### TEACHING AND SCHEME OF EXAMINATION

No. of weeks per semester: 15 weeks

Subject	Instructions		Examination			Duration
	Hours / Week	Hours / Semester	Marks			
WORKSHOP PRACTICE	3	45	Internal Assessment	Board Examination	Total	3 Hrs.
			25	75	100	

### **RATIONALE:**

Workshop practice is a basic subject for all branches of Diploma Engineering and Technology. This subject is aimed at providing basic understanding of the fundamentals of practical sections; mainly planning, marking, cutting, filing, wiring connections, standards & conventions of wiring, the tools, the use of measuring instruments in engineering applications and plumbing tools and practices.

The topics covered are based on the syllabus for Diploma studies in engineering. The subject is planned to include sufficient practices which would help the student to understand the principles of manufacturing.

### **OBJECTIVES:**

At the end of the practice, the students will be able to,

- Acquire skills in basic engineering practice.
- Identify the hand tools and instruments.
- Study and use measuring instruments.
- Practical skills in the fitting, plumbing and wiring trades.



## **30018 WORKSHOP PRACTICE**

### **1. FITTING SECTION**

**15 HRS.**

- General safety precaution inside the workshop.
- Study about first aid.
- Study of hand tools
- Study of instruments- Calipers -Scale – Vernier caliper – Vernier height gauge.
- Marking and punching practice.
- Hacksaw cutting practice.
- Filing and fitting practice.
- Drilling and tapping practice.

#### **Exercises**

**Raw material:** 3mm thick M.S. flat

1. Single piece cutting and filing
2. L-Joint
3. V-Joint
4. Drilling and tapping (Four drills and Two with Taps) **Raw material:** 10mm thick M.S. flat

**Note:** Practices should be given to cover the above area. At the end, the students should be able to do the above exercises for the board practical examinations. Students should mention the variations in the dimensions of their exercises.

### **2. WIRING**

**15 HRS**

- Study about the safety measures in wiring.
- Study of tools.
- Study about the earthing.
- Identify different electrical fitting and accessories.
- Identify the types of wires with colour code.
- Identify the symbols in circuit diagram.
- Practice simple wiring.
- Uses of multimeter.

#### **Exercises**

1. One lamp controlled by one-way switch – measure and check the voltage and current using multimeter.

2. Two lamps connected in series - measure and check the voltage and current using multimeter.
3. Two lamps connected in parallel - measure and check the voltage and current using multimeter.
4. Staircase wiring.

**Note:** Students should draw the circuit diagram and collect the components according to their requirement. Only components should be given to the students. The connection should be given from the main switch. Suitable safety precautions should be made before connections.

### **3. PLUMBING**

**15 HRS**

- Plumbing is the skilled trade of working with pipes, tubing and plumbing fixtures for drinking water systems and the drainage of waste.
- The plumbing industry is a basic and substantial part of every developed economy due to the need for clean water, and proper collection and transport of wastes.
- Plumbing also refers to a system of pipes and fixtures installed in a building for the distribution of potable water and the removal of waterborne wastes.
- Plumbing is usually distinguished from water and sewage systems, in that a plumbing system serves one building, while water and sewage systems serve a group of buildings or a city.
- To install pipes and fixtures.
- To repair or replace all kinds of leaks.
- Use personal protective equipments.

#### **Exercises**

1. Install a sink / washbasin with tap using different PVC/GI pipe accessories such as bend, tee and gate valve.
2. Cutting, bending and external threading of GI pipes using Die.
3. Repair a leakage in the water tap and fix water meter.
4. Lay pipes to install rain water harvesting.

**The students should be given training in all the sections. All the exercises should be completed. The students should maintain record notebook for the concerned trades and submit during the Board Practical Examinations.**

## FITTING EXERCISE

### 1. Single piece cutting and filing

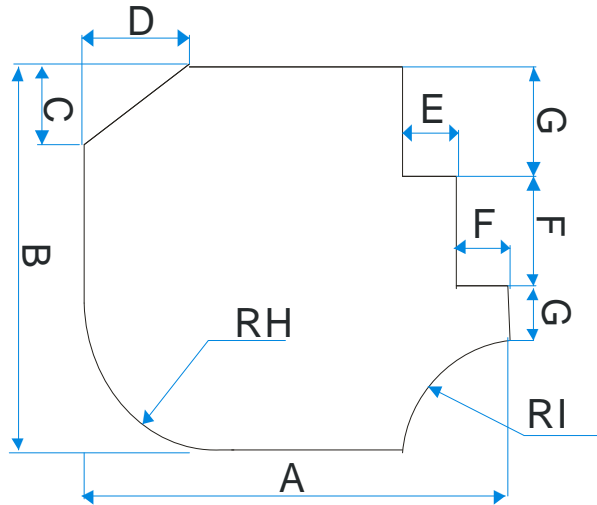

Sl.No	PART NAME	ACTUAL	OBTAINED	VARIATION
1	A			
2	B			
3	C			
4	D			
5	E			
6	F			
7	G			
8	R H			
9	R I			

### 2. L-Joint

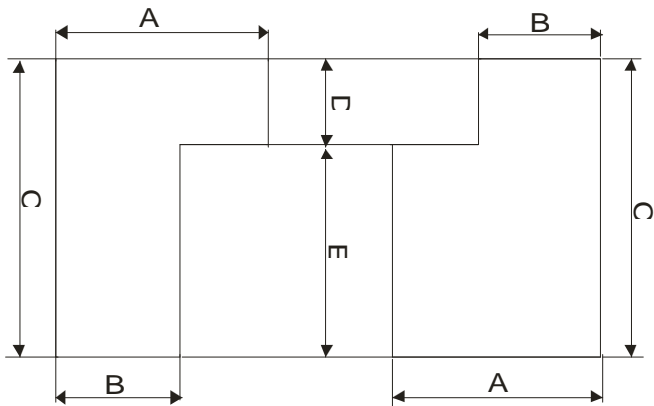

Sl.No	PART NAME	ACTUAL	OBTAINED	VARIATION
1	A			
2	B			
3	C			
4	D			
5	E			

### 3. V-Joint

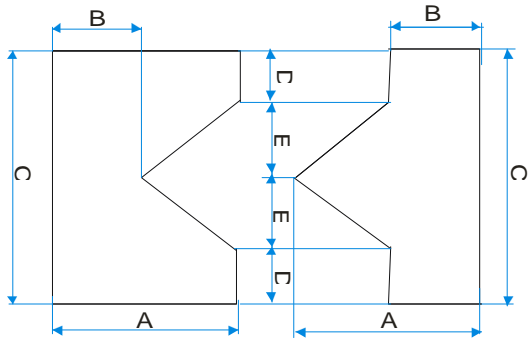

SI.No	PART NAME	ACTUAL	OBTAINED	VARIATION
1	A			
2	B			
3	C			
4	D			
5	E			

### 4. Drilling and tapping (Four drills and Two with Taps)

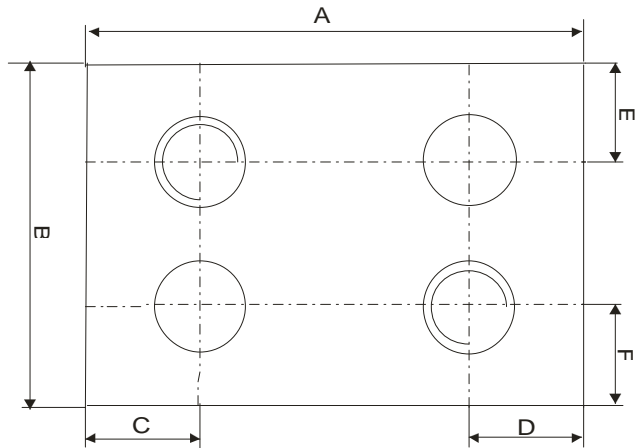

SI.No	PART NAME	ACTUAL	OBTAINED	VARIATION
1	A			
2	B			
3	C			
4	D			
5	E			
6	F			
7	Dia			
8	Tapping			

### **30018 WORKSHOP PRACTICE**

#### **BOARD EXAMINATION**

**Note:** Any two exercises should be carried out for examination. Fitting is compulsory any one exercise form wiring or plumbing. All the exercises should be given in the question paper and students are allowed to select by a lot. **Students should have liberty to do the examination for 3 Hrs. No fixed time for each trade. The number of instrument / equipment facility should be available for each batch strength during examination.**

		Max. Marks
<b>Fitting (Compulsory)</b>		<b>35</b>
Marking & Cutting	- 10	
Filing / Dimensions	- 20	
Joint / Finish	- 5	
<b>Wiring</b>		<b>35</b>
Circuit diagram	- 15	
Connection / Checking	- 15	
Result	- 5	
	<b>(OR)</b>	
<b>Plumbing</b>		<b>35</b>
Preparation of material	- 15	
Connection / Testing	- 15	
Result	- 5	
<b>Viva-voce</b>		<b>5</b>
<b>TOTAL</b>		<b>75</b>
<b>Internal Marks</b>		<b>25</b>
Observation	- 10	
Record	- 10	
Attendance	- 5	
<b>Total</b>	- <b>25</b>	

## LIST OF EQUIPMENTS REQUIRED

**NAME OF THE BRANCH / COURSE**      FIRST YEAR BASIC ENGINEERING  
**SEMESTER**                                      I SEMESTER  
**NAME OF THE LABORATORY**              WORKSHOP PRACTICE – FITTING SECTION

<b>S.No</b>	<b>LIST OF THE EQUIPMENTS</b>	<b>QUANTITY REQUIRED</b>
1.	Power Hacksaw / bar cut machine	1 No.
2.	Hand shearing machine	1 No.
3.	Surface plate	5 Nos.
4.	Anvil	5 Nos.
5.	Drilling machine	3 Nos.
6.	Calipers (Inside / odd leg / outside)	10 Nos each.
7.	Vernier caliper	5 Nos
8.	Vernier Height Gauge	2 Nos.
9.	Bench vice fitted on the table	30 Nos.
10.	Hand hacksaw Frame	30 Nos.
11.	Flat rough / smooth file	30 Nos. each
12.	Try angular file	30 Nos.
13.	Half round file	30 Nos.
14.	Try square	30 Nos.
15.	Steel rule	30 Nos.
16.	Scriber	30 Nos.
17.	Square file	10 Nos.
18.	Round file	10 Nos.
19.	Dot punch / Center punch / Prick punch	Sufficient quantity
20.	Hammer	Sufficient quantity
21.	Drill Bit (Required size)	Sufficient quantity
22.	Tap set (Required size)	Sufficient quantity
23.	Tap wrench	Sufficient quantity

**NAME OF THE BRANCH / COURSE  
SEMESTER**

FIRST YEAR BASIC ENGINEERING  
I SEMESTER

**NAME OF THE LABORATORY**

WORKSHOP PRACTICE – **WIRING SECTION**

**S.No LIST OF THE EQUIPMENTS**

**QUANTITY REQUIRED**

1. Cutting pliers (insulated)	15 Nos.
2. Wire Cutter	10 Nos.
3. Screw driver (Insulated)	15 Nos.
4. 250V Line Tester	15 Nos.
5. Wiring board (Wood)	15 Nos.
6. Screw driver set	5 Nos.
7. Hammer	5 Nos.
8. Poker	5 Nos.
9. Multi meter	5 Nos.
10. Wires	Sufficient quantity
11. Bulbs (CFL/LED)	Sufficient quantity
12. Tube light set	Sufficient quantity
13. Holders	Sufficient quantity
14. Connectors	Sufficient quantity
15. Switches (One way / Two way)	Sufficient quantity

**NAME OF THE BRANCH / COURSE** FIRST YEAR BASIC ENGINEERING  
**SEMESTER** I SEMESTER  
**NAME OF THE LABORATORY** WORKSHOP PRACTICE – **PLUMBING SECTION**

**S.No LIST OF THE EQUIPMENTS QUANTITY REQUIRED**

1. HAND-OPERATED BENDING TOOL	2 Nos.
2. SPIRIT LEVEL	5 Nos.
3. TRY SQUARE	5 Nos.
4. MEASURING TAPE	5 Nos.
5. HAND DRILLING MACHINE	2 Nos.
6. HACKSAW FRAME WITH BLADE	5 Nos.
7. JUNIOR HACKSAW FRAME	5 Nos.
8. PIPE/TUBE CUTTER	2 Nos.
9. WATER METER	5 Nos.
10. CUTTING PLIER	5 Nos.
11. GRIP PLIER	5 Nos.
12. SLIP JOINT PLIER	5 Nos.
13. SCREW DRIVER	5 Nos.
14. D/E SPANNER (6 to 32 mm)	2 Sets
15. BOX SPANNER (6 to 32 mm)	2 Sets
16. JUMPER BIT	5 Nos.
17. FLAT CHISEL	5 Nos.
18. SLEDGE HAMMER	5 Nos.
19. PIPE VICE	2 Nos.
20. PIPE DIE SETS (Various sizes)	5 Nos.
21. PIPE WRENCH	5 Nos.
22. SHIFTING SPANNER	5 Nos.
23. WIRE BRUSH	5 Nos.
24. Personal protective equipments	Sufficient quantity
25. TEFFLON TAPE / SOLUTION	Sufficient quantity
26. EMERY SHEET (Various sizes)	Sufficient quantity
27. GI Pipes & Accessories	Sufficient quantity
28. PVC pipes & Accessories	Sufficient quantity
29. OTHER CONSUMABLES	Sufficient quantity



## ANNEXURE

### STATE BOARD OF TECHNICAL EDUCATION & TRAINING, TAMILNADU DIPLOMA IN ENGINEERING / TECHNOLOGY SYLLABUS M-SCHEME

(Implements from the Academic year 2015-2016 onwards)

Course Name : All branches of Diploma in Engineering and Technology and Special Programmes except HMCT and film & TV.

Subject Code : 30021

Semester : II Semester

Subject Title : **COMMUNICATION ENGLISH – II**

#### TRAINING AND SCHEME OF EXAMINATION:

No. of Weeks per Semester: 15 Weeks

Subject	Instructions		Examination			Duration
	Hours / Week	Hours / Semester	Marks			
Communication English- II	5 Hrs.	75 Hrs.	Internal Assessment	Semester Examination	Total	3 Hrs
			25	75	100	

### 30021 COMMUNICATION ENGLISH - II

#### DETAILED SYLLABUS

#### Contents: Theory

Content	Competencies	Transactional Strategies	Learning Outcomes	Contact Hrs.
<b>Unit 1</b>  <b>Matter</b>	Grammar  <b>Active/Passive</b>	Through Activities  Presentation, practice, use Presentation of rules Adequate contextual examples. Practice	Recognize & distinguish active/passive forms Use active & passive forms	7
	<b>Direct to indirect</b>	Tasks	Convert from direct to indirect, Indirect to direct	3
	Reading & Writing	Tasks based complex texts	Respond to, interpret and analyze texts for academic purposes Complete cloze Summarize texts in own words	5
	Vocabulary <b>Lexical sets</b>	Activity	Build and expand vocabulary use.	

<b>Unit 2</b>  <b>Polymers</b>	Reading	Task based complex passages for academic purposes. Factual, Inferential Vocabulary & Experiential questions	Comprehend, interpret, analyze texts	6
	Grammar  <b>Word forms</b> <b>Tags</b> <b>Prefix/suffix</b>	Activities  Presentation, practice, use Presentation Adequate contextual examples Practice	Identify, recognize, use word forms appropriately Convert words into other forms Add question tags Use prefix/suffix appropriately	7
	Speaking	Activity: Pair work Information Gap	Speak on given frames in pairs	2
<b>Unit 3</b>  <b>Disasters</b>	Grammar  <b>Degrees of Comparison</b>	Activities  Presentation, practice, uses Presentation of structure & rules Adequate contextual examples Practice.	Sort positive, comparative, superlative forms  Recognize, distinguish & use degrees appropriately.	5
	<b>Verbal questions</b>  <b>Wh questions</b>	Activities Presentation, Practice, uses Presentation of structure & rules Adequate contextual examples Practice.	Use verbal questions in contexts  Use Wh questions in contexts	5
	Reading	Task based Factual Inferential Vocabulary & Experiential Questions	Comprehend, interpret & analyze texts for academic purposes	2
	Speaking	Opining Activities Gap: Pair/group work	Speak on given situation to register one's opinion.	3
<b>Unit 4</b>	Writing  <b>Reports</b> <b>Hints</b> <b>Emails</b>	5-Step Writing Process - Pre writing (brainstorming)  - Clustering/Grouping - Rough draft - Revision/Editing - Final draft	Recognize structure of reports Use passive forms to write Develop hints by framing sentences & write paragraphs Recognize internalize the structure & compose emails	15

<b>Unit 5</b>	Writing  <b>Formal letter</b> <b>Resume</b> <b>Verbal to visual</b>	Activities: tasks Job application ordering goods.  Lodging complaints (sample, guided, controlled, free)	Recognize & internalize structure & write letters: applying for jobs, complaints, placing orders.  Write own resumes.	15
	Reading	Task based Factual Inferential Vocabulary & Experiential Questions	Respond, interpret & analyze passages for academic purposes.	

# MODEL QUESTION PAPER

## Semester - II

Time: 3 Hours

Maximum Marks: 75

I. Answer any ten of the following:

10 x 3 = 30

1. Write 3 words related to 'school'.

2. Match the following with the relevant opposite word.

- |              |   |             |
|--------------|---|-------------|
| a) idle      | X | begin       |
| b) basic     | X | ugly        |
| c) foolish   | X | slow        |
| d) fast      | X | active      |
| e) end       | X | advanced    |
| f) beautiful | X | intelligent |

3. Write the synonyms using the words given in brackets.

- |                |       |                                  |
|----------------|-------|----------------------------------|
| a) shut        | ----- | (open / close / end)             |
| b) complete    | ----- | (final / relevant / part)        |
| c) fundamental | ----- | (secondary / advanced / primary) |

4. Convert the following verbs into nouns.

- |         |            |         |
|---------|------------|---------|
| a) sing | b) examine | c) free |
|---------|------------|---------|

5. Convert the following nouns into verbs.

- |               |               |               |
|---------------|---------------|---------------|
| a) exhibition | b) punishment | c) derivation |
|---------------|---------------|---------------|

6. Convert the following verbs into adjectives.

- |         |         |             |
|---------|---------|-------------|
| a) play | b) risk | c) beautify |
|---------|---------|-------------|

7. Identify the Degrees of comparison and write as positive degree / comparative degree / superlative degree for the following sentences.

- Rama is the cleverest boy in the class.
- This cell tower is taller than our building.
- Black colour is not as bright as yellow.

8. Write suitable prefixes for the following words.

- |           |         |             |
|-----------|---------|-------------|
| a) proper | b) able | c) pleasure |
|-----------|---------|-------------|

9. Write suitable suffixes for the following words.

- |         |            |            |
|---------|------------|------------|
| a) free | b) meaning | c) develop |
|---------|------------|------------|

**10. Identify and write the passive verb in the following sentences.**

a) People weren't forced to buy anything when they were in an exhibition.

b) The students have been informed to bring their textbooks, without fail.

c) Some questions are being asked from the exercises which are in the book for the examination.

**11. Choose and fill in the blanks with suitable prepositions / articles.**

a) Peter goes \_\_\_\_ bus to \_\_\_\_ theatre. (by/in/an/the)

b) Nathan buys \_\_\_\_ watch \_\_\_\_ the Titan Show-room. (the/a/on/from)

c) Senthil wants to eat \_\_\_\_ apple which is \_\_\_\_\_ Himachal Pradesh.  
(a/an/from/in)

**12. Answer the following verbal question first in affirmative and then in negative.**

Do you like to drink coffee?

**II. Answer any five of the following:**

**5 x 3 = 15**

**1. Identify and write as active / passive sentence against each of the following.**

a) They are playing football.

b) I have read a book.

c) The class test was conducted by my teacher.

**2. Convert the dialogue into reported speech.**

Ravi: Where are you going?

Gopi: I am going to the market.

**3. Supply suitable tags for the following sentences.**

a) They went to Chennai.

b) We don't like to swim.

c) He is my dearest friend.

**4. Fill in the blanks with suitable tense forms of the verbs given in the brackets.**

Substances \_\_\_\_ (be) made up of smaller particles which \_\_\_\_\_ (move) around. Some of these particles \_\_\_\_\_ (split) further into yet smaller particles.

**5. Correct the errors in the following sentences.**

- a) He going to the market.
- b) Water has flown to the fields.
- c) We are fond in music.

**6. Convert the following into direct speech.**

My mother asked me if I had taken my breakfast. I replied to her that I had taken it at my friend's home.

**7. Match the following idioms/phrases with their relevant meaning.**

- |                   |                                 |
|-------------------|---------------------------------|
| a. this or that   | 1. In human relationships       |
| b. dos and don'ts | 2. Efforts taken                |
| c. friend or foe  | 3. Options that can be explored |
|                   | 4. Instructions                 |

**8. A man approaches you to direct him to a nearby hospital. Write three instructions.**

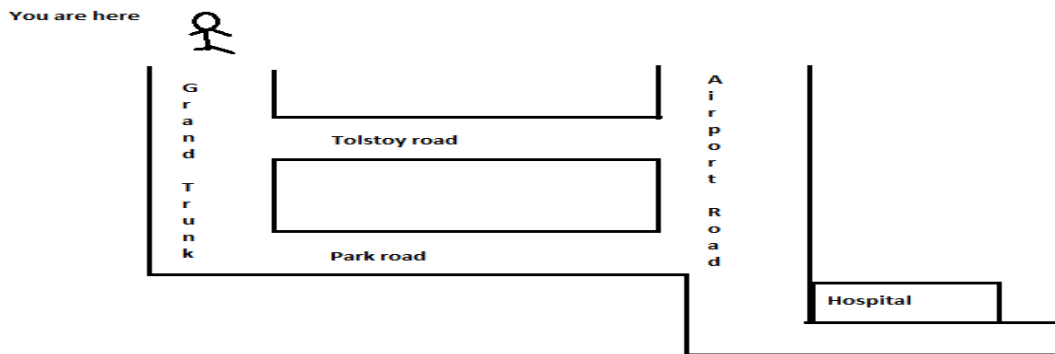

**III. Answer the following questions as directed.**

**3 x 5 = 15**

**1. Read the questions and find the answers in the newspaper report.**

- a) What was the 8<sup>th</sup> international conference about?
- b) Which is under the 'conceptual stage'?
- c) When is the manned expedition to moon expected to be carried out?
- d) Give the full form of IAA and ASI.
- e) How much did India spend for launching Chandrayaan-1?

**Panaji:** Indian Space Research Organization Chairman Mr. G. Madhavan Nair indicated on Monday that India planned to launch a mission to explore Mars. It was under the conceptual stage.

Mr. Nair was addressing the inaugural session of the 8<sup>th</sup> International Conference on 'Low Cost Planetary Missions' here. He said ISRO was poised to launch the Chandrayaan-2 mission to land on the Moon and conduct experiments in 2012-13. This would be followed by a manned expedition to the Moon in 2015 and plans to explore Mars, later.

The five-day conference, organized by ISRO in collaboration with the International Academy of Astronautics (IAA) and the Astronautically Society of India (ASI), was inaugurated by Chief Minister Mr. Digambar Kamat. The Goa Minister for Science and Technology Mr. Churchill Alemao was also present.

Speaking about low-cost planetary missions, Mr. Nair said India had set a trend in building low-cost satellites with Chandrayaan-1 being the best example. It was below \$100 million as compared to the nearly \$500 million that were spent on similar expeditions by other developed countries.

**2. You wish to apply for the post of "supervisor" in a Multi-national Company. Write a resume, with a cover letter.**

**3. Place an order for the purchase of sports items for your college.**

**IV. Answer any three of the following:**

**3 x 5 = 15**

**1. Write a short report (in 50 words) of the process of preparing lemon juice / any item you think of / lab report / news report.**

**2. Convert the verbal text into a visual representation (graphics/ flow chart)**

The solar system

Our solar system consists of the sun, the nine planets and the asteroids, comets and meteoroids that are associated with the planets. The nine planets that make up our solar system are Mercury, Venus, Earth, Mars, Jupiter, Uranus, Neptune and Pluto. Mercury is closest to the sun. It is hot and dry. Venus is one of the brightest objects in the sky after the sun and the moon. Venus is also the hottest planet in the solar system. Next is the Earth, the only living planet. After Earth is Mars which is also called the Red Planet. Mars is very dry now.

Jupiter is the largest planet. Its bright colour comes from its clouds. Saturn is the second largest planet and has wide rings. The planet Uranus is a bright blue colour. After Uranus is Neptune. Neptune rotates around the sun once in every 164 years. Pluto is the farthest planet from the sun.

**3. Write an email to your friend inviting him to spend the weekend at Mahabalipuram.**

**4. Convert the following table into a paragraph of 50 words.**

**Placement details of XYZ Polytechnic in 2015**

<b>Branch</b>	<b>Accenture</b>	<b>IBM</b>	<b>TCS</b>
Civil	10	25	45
Mechanical	50	30	55
Electrical	30	45	70
Electronics	20	35	20

**5. Develop the following hints into a passage of about 50 words.**

Books – best companions – some books entertain – time pass – other books instruct us – enrich knowledge – improve logical thinking – reasoning ability – overall – treasure house of knowledge

**\*\* Note: Guide line for setting the question paper is given in the Annexure - I**



## **Annexure – I**

### **Guidelines for setting question paper**

#### **Semester – II**

**Vocabulary based questions like (Q 1.3, 1.4, 1.5, 1.6, 1.8 &1.9) may be taken from the textbook.**

#### **Q 3.1 comprehension**

- ❖ Question should precede the paragraph

#### **Q 2.4 tense forms**

- ❖ A para with 3 blanks with verbs in brackets should be given

#### **Q 2.7 Idioms & phrases**

- ❖ Idioms & phrases should be taken from the prescribed text book only

#### **Q 4.2 process**

- ❖ Questions on process should be given such as
  - preparing fruit juice / Coffee / Tea / Planting a sapling
  - Chemistry, Physics and workshop practical process

#### **Q 4.1 verbal to visual**

- ❖ Paragraphs should be selected in such a way that they lend themselves to converting into graphics / flow chart / bar chart / pie chart or table

#### **Q 4.5 Hints Development**

- ❖ Topics related to science, environment , technology should be given

## ANNEXURE

### STATE BOARD OF TECHNICAL EDUCATION & TRAINING, TAMILNADU DIPLOMA IN ENGINEERING / TECHNOLOGY - SYLLABUS M-SCHEME

(Implements from the Academic Year 2015-2016 onwards)

Course Name : All branches of Diploma in Engineering and Technology and Special Programmes except DMOP, HMCT and film & TV.

Subject Code : 30022

Semester : II Semester

Subject Title : **ENGINEERING MATHEMATICS – II**

#### TEACHING AND SCHEME OF EXAMINATION:

**No of weeks per semester: 15 weeks**

Subject	Instructions		Examination			Duration
	Hours / Week	Hours / Semester	Marks			
Engineering Mathematics - II	5 Hrs.	75 Hrs.	Internal Assessment	Semester Examination	Total	3 Hrs
			25	75	100	

#### TOPICS AND ALLOCATION OF HOURS:

Sl.No.	Topics	Time (Hrs.)
1	Analytical Geometry	14
2	Vector Algebra – I	14
3	Vector Algebra – II	14
4	Integral Calculus – I	14
5	Integral Calculus – II	14
Test and Tutorial		5
TOTAL		<b>75</b>

**Rationale:** In many fields of Engineering, there are situations where in the effects due to various factors can be calculated only in a smaller region. To calculate the total effect or effect over a larger region the Integration concept is used. Integration plays vital role in many fields of Engineering.

**Objectives:** The student will be able to acquire knowledge of algebra of vectors and its application in finding work done, moment, volumes, to acquire knowledge of Integration principles and different methods of Integration.

## 30022 ENGINEERING MATHEMATICS - II

### DETAILED SYLLABUS

#### Contents: Theory

UNIT	NAME OF TOPICS	Hours
<b>I</b>	<b>ANALYTICAL GEOMETRY</b>	<b>5</b>
	<b>Chapter - 1.1 EQUATION OF CIRCLE</b> Equation of circle – given centre and radius. General equation of circle – finding centre and radius. Equation of circle on the line joining the points $(x_1, y_1)$ and $(x_2, y_2)$ as diameter. Simple Problems.	
	<b>Chapter - 1.2 FAMILY OF CIRCLES</b> Concentric circles, contact of two circles (Internal and External) -Simple problems. Orthogonal circles (results only). Problems verifying the condition .	<b>4</b>
	<b>Chapter - 1.3 INTRODUCTION TO CONIC SECTION</b> Definition of a Conic, Focus, Directrix and Eccentricity. General equation of a conic $ax^2 + 2hxy + by^2 + 2gx + 2fy + c = 0$ (statement only). Condition for conic (i) for circle: $a = b$ and $h = 0$ (ii) for pair of straight line: $\begin{vmatrix} a & h & g \\ h & b & f \\ g & f & c \end{vmatrix} = 0$ (iii) for parabola: $h^2 - ab = 0$ (iv) for ellipse: $h^2 - ab < 0$ and (v) for hyperbola: $h^2 - ab > 0$ . Simple Problems.	<b>5</b>
<b>II</b>	<b>VECTOR ALGEBRA – I</b>	<b>5</b>
	<b>Chapter - 2.1 VECTOR - INTRODUCTION</b> Definition of vector - types, addition, and subtraction of Vectors, Properties of addition and subtraction. Position vector. Resolution of vector in two and three dimensions. Direction cosines, Direction ratios. Simple problems.	
	<b>Chapter - 2.2 SCALAR PRODUCT OF VECTORS</b> Definition of Scalar product of two vectors – Properties – Angle between two vectors. Simple Problems.	<b>5</b>
	<b>Chapter - 2.3 APPLICATION OF SCALAR PRODUCT</b> Geometrical meaning of scalar product. Work done by Force. Simple Problems.	<b>4</b>
<b>III</b>	<b>VECTOR ALGEBRA – II</b>	<b>5</b>
	<b>Chapter - 3.1 VECTOR PRODUCT OF TWO VECTORS</b> Definition of vector product of two vectors. Geometrical meaning. Properties – Angle between two vectors – unit vector perpendicular to two vectors. Simple Problems.	

UNIT	NAME OF TOPICS	Hours
III	<b>Chapter - 3.2 APPLICATION OF VECTOR PRODUCT OF TWO VECTORS &amp; SCALAR TRIPLE PRODUCT</b> Definition of moment of a force. Definition of scalar product of three vectors – Geometrical meaning – Coplanar vectors. Simple Problems.	5
	<b>Chapter - 3.3 VECTOR TRIPLE PRODUCT &amp; PRODUCT OF MORE VECTORS</b> Definition of Vector Triple product, Scalar and Vector product of four vectors Simple Problems.	4
IV	<b>INTEGRAL CALCULUS – I</b>	5
	<b>Chapter - 4.1 INTEGRATION – DECOMPOSITION METHOD</b> Introduction - Definition of integration – Integral values using reverse process of differentiation – Integration using decomposition method. Simple Problems.	
	<b>Chapter - 4.2 INTEGRATION BY SUBSTITUTION</b> Integrals of the form $\int [f(x)]^n f'(x)dx, n \neq -1$ , $\int \frac{f'(x)}{f(x)}dx$ and $\int F[f(x)]f'(x)dx$ . Simple Problems.	5
	<b>Chapter - 4.3 STANDARD INTEGRALS</b> Integrals of the form $\int \frac{dx}{a^2 \pm x^2}$ , $\int \frac{dx}{x^2 - a^2}$ and $\int \frac{dx}{\sqrt{a^2 - x^2}}$ . Simple Problems	4
V	<b>INTEGRAL CALCULUS – II</b>	5
	<b>Chapter - 5.1 INTEGRATION BY PARTS</b> Integrals of the form $\int x \sin nx dx$ , $\int x \cos nx dx$ , $\int x e^{nx} dx$ , $\int x^n \log x dx$ and $\int \log x dx$ . Simple Problems.	
	<b>Chapter - 5.2 BERNOULLI'S FORMULA</b> Evaluation of the integrals $\int x^m \sin nx dx$ , $\int x^m \cos nx dx$ and $\int x^m e^{nx} dx$ where $m \leq 2$ using Bernoulli's formula. Simple Problems.	4
	<b>Chapter - 5.3 DEFINITE INTEGRALS</b> Definition of definite Integral. Properties of definite Integrals - Simple Problems.	5

**Text Book:**

1. Mathematics for Higher Secondary – I year and II year (Tamil Nadu Text Book Corporation)
- 2.

**Reference Book:**

1. Engineering Mathematics - Dr.M.K.Venkatraman, National Publishing Co, Chennai
2. Engineering Mathematics – Dr.P.Kandasamy & Others, S.Chand & Co Ltd, New Delhi.

## Board Examination - Question paper pattern

Time: 3 Hrs.

Max.Marks: 75

**PART A** - 5 Questions to be answered out of 8 for 2 marks each.

**PART B** - 5 Questions to be answered out of 8 for 3 marks each.

**PART C** - All the 5 Questions to be answered

Each question in PART C will contain 3 Sub questions, out of these 3 Sub questions 2 Sub questions is to be answered for 5 marks each.

<b>PART A</b>	5 x 2 marks	10 Marks
<b>PART B</b> Short answer type questions	5 x 3 marks	15 Marks
<b>PART C</b> Descriptive answer type questions Each question in PART C will contain 3 Sub questions, out of these 3 Sub questions 2 Sub questions is to be answered for 5 marks each.	5 x 2 x 5 marks	50 Marks
Total		75 Marks

Out of the 3 Sub questions in PART C, one sub question must be on problem based to test the analytical ability/logical ability /diagnostic ability/conceptual ability relevant to that subject content. Equal weightage is to be given to whole syllabus.

Clarks table will not be permitted for the Board Examinations.

## ANNEXURE

### STATE BOARD OF TECHNICAL EDUCATION & TRAINING, TAMILNADU DIPLOMA IN ENGINEERING / TECHNOLOGY - SYLLABUS M-SCHEME

(Implements from the Academic Year 2015-2016 onwards)

Course Name : All branches of Diploma in Engineering and Technology and Special Programmes except DMOP, HMCT and film & TV.  
Subject Code : 30023  
Semester : II Semester  
Subject Title : **APPLIED MATHEMATICS**

#### **TEACHING AND SCHEME OF EXAMINATION:**

**No of weeks per semester: 15 weeks**

Subject	Instructions		Examination			Duration
	Hours / Week	Hours / Semester	Marks			
Applied Mathematics	5 Hrs.	75 Hrs.	Internal Assessment	Semester Examination	Total	3 Hrs
			25	75	100	

#### **TOPICS AND ALLOCATION OF HOURS:**

Sl. No.	Topics	Time (Hrs.)
1	Probability Distribution – I	14
2	Probability Distribution – II	14
3	Application of Differentiation	14
4	Application of Integration – I	14
5	Application of Integration – II	14
Test and Tutorial		5
TOTAL		75

#### **Rationale:**

Many of Physical Engineering Problems like vibration of two side tied strings, Heat flow, decaying of radioactive material comes only in the form of differential equation, solution of differential equation gives solution of Physical Problems.

#### **Objectives:**

This subject helps the students to acquire knowledge of finding areas and volumes using Integration and various methods of solving first and second order differential equations. This subject also helps the students to become aware of Binomial, Poisson and Normal distributions which can be used in Quality control.

## 30023 APPLIED MATHEMATICS

### DETAILED SYLLABUS

#### Contents: Theory

UNIT	NAME OF TOPICS	Hours
<b>I</b>	<b>PROBABILITY DISTRIBUTION – I</b>	5
	<b>Chapter - 1.1 RANDOM VARIABLE</b> Definition of Random variable – Types – Probability mass function – Probability density function. Simple Problems.	
	<b>Chapter - 1.2 MATHEMATICAL EXPECTATION</b> Mathematical Expectation of discrete random variable, mean and variance. Simple Problems.	4
	<b>Chapter - 1.3 BINOMIAL DISTRIBUTION</b> Definition of Binomial distribution $P(X = x) = {}^n C_x p^x q^{n-x}$ where $x = 0, 1, 2, \dots$ Statement only. Expression for mean and variance. Simple Problems.	5
<b>II</b>	<b>PROBABILITY DISTRIBUTION – II</b>	5
	<b>Chapter - 2.1 POISSON DISTRIBUTION</b> Definition of Poisson distribution $P(X = x) = \frac{e^{-\lambda} \cdot \lambda^x}{x!}$ where $x = 0, 1, 2, \dots$ (statement only). Expressions of mean and variance. Simple Problems.	
	<b>Chapter - 2.2 NORMAL DISTRIBUTION</b> Definition of normal and standard normal distribution – statement only. Constants of normal distribution (Results only). Properties of normal distribution - Simple problems using the table of standard normal distribution.	5
	<b>Chapter - 2.3 CURVE FITTING</b> Fitting of straight line using least square method (Results only). Simple problems.	4
<b>III</b>	<b>APPLICATION OF DIFFERENTIATION</b>	5
	<b>Chapter – 3.1 VELOCITY AND ACCELERATION</b> Velocity and Acceleration – Simple Problems.	
	<b>Chapter - 3.2 TANGENT AND NORMAL</b> Tangent and Normal – Simple Problems.	4
	<b>Chapter - 3.3 MAXIMA AND MINIMA</b> Definition of increasing and decreasing functions and turning points. Maxima and Minima of single variable only – Simple Problems.	5

UNIT	NAME OF TOPICS	Hours
IV	<b>APPLICATION OF INTEGRATION – I</b>	5
	<b>Chapter - 4.1 AREA AND VOLUME</b> Area and Volume – Area of Circle. Volume of Sphere and Cone – Simple Problems.	
	<b>Chapter - 4.2 FIRST ORDER DIFFERENTIAL EQUATION</b> Solution of first order variable separable type differential equation .Simple Problems.	5
	<b>Chapter - 4.3 LINEAR TYPE DIFFERENTIAL EQUATION</b> Solution of linear differential equation. Simple problems.	4
V	<b>APPLICATION OF INTEGRATION – II</b>	4
	<b>Chapter – 5.1 SECOND ORDER DIFFERENTIAL EQUATION – I</b> Solution of second order differential equation with constant coefficients in the form $a\frac{d^2y}{dx^2} + b\frac{dy}{dx} + cy = 0$ where $a, b$ and $c$ are constants. Simple Problems.	
	<b>Chapter - 5.2 SECOND ORDER DIFFERENTIAL EQUATION – II</b> Solution of second order differential equations with constant coefficients in the form $a\frac{d^2y}{dx^2} + b\frac{dy}{dx} + cy = f(x)$ where $a, b$ and $c$ are constants and $f(x) = ke^{mx}$ . Simple Problems.	5
	<b>Chapter - 5.3 SECOND ORDER DIFFERENTIAL EQUATION – III</b> Solution of second order differential equation with constant coefficients in the form $a\frac{d^2y}{dx^2} + b\frac{dy}{dx} + cy = f(x)$ where $a, b$ and $c$ are constants and $f(x) = k \sin mx$ or $k \cos mx$ . Simple Problems.	5

**Text Book:**

1. Mathematics for Higher Secondary – I year and II year (Tamil Nadu Text Book Corporation)

**Reference Book:**

1. Engineering Mathematics - Dr.M.K.Venkatraman, National Publishing Co, Chennai
2. Engineering Mathematics – Dr.P.Kandasamy & Others, S.Chand & Co Ltd, New Delhi.



## Board Examination - Question paper pattern

Time: 3 Hrs.

Max.Marks: 75

**PART A** - 5 Questions to be answered out of 8 for 2 marks each.

**PART B** - 5 Questions to be answered out of 8 for 3 marks each.

**PART C** - All the 5 Questions to be answered

Each question in PART C will contain 3 Sub questions, out of these 3 Sub questions 2 Sub questions is to be answered for 5 marks each.

<b>PART A</b>	5 x 2 marks	10 Marks
<b>PART B</b> Short answer type questions	5 x 3 marks	15 Marks
<b>PART C</b> Descriptive answer type questions Each question in PART C will contain 3 Sub questions, out of these 3 Sub questions 2 Sub questions is to be answered for 5 marks each.	5 x 2 x 5 marks	50 Marks
Total		75 Marks

Out of the 3 Sub questions in PART C, one sub question must be on problem based to test the analytical ability/logical ability /diagnostic ability/conceptual ability relevant to that subject content. Equal weightage is to be given to whole syllabus.

Clarks table will not be permitted for the Board Examinations.

## ANNEXURE

**STATE BOARD OF TECHNICAL EDUCATION & TRAINING, TAMILNADU**  
**DIPLOMA IN ENGINEERING / TECHNOLOGY SYLLABUS**  
**M-SCHEME**  
**(Implements from the Academic year 2015-2016 onwards)**

Course Name : All branches of Diploma in Engineering and Technology and Special Programmes except DMOP, HMCT and film & TV.

Subject Code : 30024

Semester : II Semester

Subject Title : **ENGINEERING PHYSICS – II**

### TEACHING AND SCHEME OF EXAMINATION:

No of weeks per semester: 15 weeks

Subject	Instructions		Examination			Duration
	Hours / Week	Hours / Semester	Marks			
			Internal Assessment	Board Examination	Total	
ENGINEERING PHYSICS II	5 Hrs	75 Hrs	25	75	100	3Hrs

### Topics and Allocation of Hours:

Sl.No	Topic	Time(Hrs)
1	HEAT	13
2	THERMODYNAMICS, LIQUEFACTION OF GASES& NON-CONVENTIONAL ENERGY	13
3	LIGHT AND REMOTE SENSING	13
4	ELECTRICITY	13
5	ELECTRONICS	13
6	REVISION+TEST+MODEL EXAM	10
<b>Total</b>		<b>75</b>

## **RATIONALE:**

The exponential growth of Engineering and Technology has benefited the mankind with extreme sophistication and comfort. To sustain this development, continuous research and development should take place not only in Engineering and Technology but also in Basic Science such as Physics.

The various divisions of Physics like Heat, Optics, Acoustics, Semiconductor Physics, Nuclear Physics, Energy Studies, Materials Science, etc provide the foundation by enlightening the **Fundamental facts, Principles, Laws and Correct sequence of events** to develop the Engineering and Technology field for the prosperity of human beings.

## **OBJECTIVES:**

At the end of the study of II Semester the student will be able to

- Identify good conductors and insulators of heat.
- Analyze the relation between pressure, volume and temperature of gas and to interpret the results.
- Understand the process of Isothermal and Adiabatic changes of gas and basic laws of thermodynamics.
- Acquire knowledge about liquefaction process of gases.
- Realize the inevitable need for tapping Alternate energy to address the looming energy crisis.
- Identify the characteristics and properties of LASER, Optical fiber.
- Acquire broader ideas about the process of remote sensing in tapping the earth resources for human benefits.
- Acquire knowledge about heating, chemical and magnetic effects of electric current.
- Gain broader ideas of capacitors, diodes, transistors, integrated circuits and logic gates.
- Identify, analyze and solve Engineering field related problems involving expressions derived in all the above topics.

**30024-ENGINEERING PHYSICS – II**  
**DETAILED SYLLABUS**

**Contents: Theory**

<b>Unit</b>	<b>Name of the Topic</b>	<b>Hours</b>
I	<b>HEAT</b>	
	<p><b><u>1.1 TRANSFER OF HEAT</u></b></p> <p>Concept of Heat and Temperature - Centigrade, Fahrenheit and Kelvin scales of temperature measurement- Conduction, convection and radiation - Definitions and explanations- Coefficient of thermal conductivity- Definition and SI unit- good and poor conductors- Examples- Properties of thermal radiation.</p>	4Hrs
	<p><b><u>1.2 KINETIC THEORY OF GASES</u></b></p> <p>Postulates – Mean square velocity and Root Mean Square (RMS) velocity of molecules- Definitions and expressions – Expression for the pressure of a gas on the basis of postulates of kinetic theory of gases - Relation between pressure and kinetic energy, pressure and absolute temperature of the gas – Simple problems based on the expression for the pressure of a gas.</p>	5Hrs
	<p><b><u>1.3 SPECIFIC HEAT CAPACITY</u></b></p> <p>Specific heat capacity of a substance (solids and liquids) – Definition – Specific heat capacity of a gas at constant volume – Specific heat capacity of a gas at constant pressure – Ratio of specific heat capacities – Explanation for <math>C_p</math> is greater than <math>C_v</math> – Derivation of Mayer's relation – calculation of Universal gas constant <math>R</math> from the gas equation <math>PV = RT</math>. Simple problems based on Mayer's relation.</p>	4Hrs
II	<b>THERMODYNAMICS, LIQUEFACTION OF GASES - AND NON CONVENTIONAL ENERGY</b>	
	<p><b><u>2.1 THERMODYNAMICS</u></b></p> <p>First law of thermodynamics – Statement- Isothermal and Adiabatic changes - Explanation – Equations for isothermal and adiabatic changes (No derivation) Simple problems..based on equations <math>P_1V_1 = P_2V_2</math> and <math>P_1V_1^\gamma = P_2V_2^\gamma</math> Second law of thermodynamics – Clausius statement and Kelvin's statement – Working of Carnot's reversible engine with indicator diagram and its efficiency.</p>	5Hrs
	<p><b><u>2.2 LIQUEFACTION OF GASES</u></b></p> <p>Critical temperature, critical pressure and critical volume – Definitions – Principle used in cascade process – Cascade process of liquefaction of oxygen – Disadvantages of cascade process - Joule Thomson effect – Temperature of inversion – Liquefaction of air by Linde's process</p>	5Hrs

	<p><b><u>2.3 NON – CONVENTIONAL ENERGY</u></b></p> <p>Introduction – Non-renewable and Renewable (Alternate) energy sources – Examples – Solar energy, wind energy, – Advantages and disadvantages of renewable energy.</p>	3Hrs
III	<p><b>LIGHT AND REMOTE SENSING</b></p> <p><b><u>3.1 OPTICS</u></b></p> <p>Refraction – Laws of refraction – Refractive index of a medium – Definition – Spectrometer – Derivation of refractive index of glass prism using minimum deviation-Experimental determination of refractive index using spectrometer- Fiber optics – Introduction – Phenomenon of total internal reflection – problems using the refractive index .</p> <p><b><u>3.2 LASER</u></b></p> <p>LASER – Characteristics of LASER – principle of LASER – Spontaneous emission – Stimulated emission – population inversion – Ruby laser- Construction and working- Uses of LASER.</p> <p><b><u>3.3 REMOTE SENSING</u></b></p> <p>Remote sensing – Introduction – Active and passive remote sensing – Explanation and examples – Components of remote sensing – Data acquisition, data analysis and reference data – RADAR – principle and working with block diagram.</p>	5Hrs  4Hrs  4Hrs
IV	<p><b>ELECRICITY</b></p> <p><b><u>4.1 ELECTRICAL CIRCUITS</u></b></p> <p>Ohm's law – Laws of resistances – Resistivity, Conductivity, Super conductivity and Meissner effect- Definitions – Kirchhoff's current and voltage laws – Condition for balancing the Wheatstone's bridge .Simple problems based on expression for resistivity.</p> <p><b><u>4.2 EFFECTS OF CURRENT</u></b></p> <p>Joule's law of heating – Experimental determination of specific heat capacity of a liquid using Joule's calorimeter – Faraday's laws on electrolysis – Electro chemical equivalent(e.c.e) of an element – Definition – Experimental determination of e.c.e. of copper- Capacitance of a capacitor – Definition – ' farad ' – Definition– expressions for effective capacitance when capacitors are connected in series and in parallel – Simple problems based on expressions for e.c.e., effective capacitance for series and parallel connections of capacitors.</p>	4Hrs  4Hrs

V	<p><b><u>4.3 MEASURING INSTRUMENTS</u></b>          Expression for the force acting on a current carrying straight conductor placed in a uniform magnetic field – Fleming’s Left Hand rule – Expression for the torque experienced by a rectangular current carrying coil placed inside a uniform magnetic field – Working of a moving coil galvanometer and its merits – Conversion of galvanometer into an Ammeter and Voltmeter. Simple problems based on conversion of galvanometer into ammeter and voltmeter.</p>	5Hrs
	<p><b>ELECTRONICS</b>  <b><u>5.1 SEMI CONDUCTORS</u></b>          Semi conductors – Energy bands in solids – Energy band diagram of good conductors, insulators and semi conductors– Concept of Fermi level - Intrinsic semiconductors -Concept of holes - Doping – Extrinsic semiconductors – P type and N type semiconductors.</p>	4Hrs
	<p><b><u>5.2 DIODES AND TRANSISTORS</u></b>          P-N junction diode – Forward bias and reverse bias –Rectification action of diode – Working of full wave rectifier using P N junction diodes -PNP and NPN transistors – Three different configurations –Advantages of common emitter configuration – Working of NPN transistor as an amplifier in common emitter configuration.</p>	5Hrs
	<p><b><u>5.3 DIGITAL ELECTRONICS</u></b>          Digital electronics – Introduction – Logic levels – Basic logic gates: OR, AND , NOT gates – Universal logic gates:NAND and NOR gates – Symbolic representation, Boolean expression and Truth table for all above logic gates – Integrated circuits– Levels of integration – SSI, MSI, LSI and VLSI-Advantages of ICs.</p>	4Hrs

**Text Book :**

1. Engineering Physics ,DOTE, Tamil Nadu
2. Physics – Higher secondary – First & Second year– Volume I & II –TamilNadu Text Book Corporation - 2004 & 2005.

**Reference Book :**

1. Fundamentals of physics – Brijlal and Subramaniam.
2. Fundamentals of Electricity – D.N. Vasudeva – S. Chand & co
3. Non- Conventional energy sources – G.D. Rai.- Khanna publishers
4. Text book of Remote sensing and Geographical information systems – M. Anji Reddy BS publications.

## Board Examination - Question paper pattern

Time: 3 Hrs.

Max.Marks: 75

**PART A** - 5 Questions to be answered out of **8** for 2 marks each.

**PART B** - 5 Questions to be answered out of **8** for 3 marks each.

**PART C** - All the **5** Questions to be answered

Each question in PART C will contain **3** Sub questions, out of these **3** Sub questions **2** Sub questions is to be answered for 5 marks each.

<b>PART A</b>	<b>5 x 2 marks</b>	<b>10 Marks</b>
<b>PART B</b> Short answer type questions	<b>5 x 3 marks</b>	<b>15 Marks</b>
<b>PART C</b> Descriptive answer type questions Each question in PART C will contain <b>3</b> Sub questions, out of these <b>3</b> Sub questions <b>2</b> Sub questions is to be answered for 5 marks each.	<b>5 x 2 x 5 marks</b>	<b>50 Marks</b>
Total		<b>75 Marks</b>

Out of the **3 Sub questions** in **PART C**, **one sub question** must be on problem based to test the analytical ability/logical ability /diagnostic ability/conceptual ability relevant to that subject content. Equal weightage is to be given to whole syllabus.

Clarks table will not be permitted for the Board Examinations.

## ANNEXURE

### STATE BOARD OF TECHNICAL EDUCATION & TRAINING, TAMILNADU DIPLOMA IN ENGINEERING / TECHNOLOGY SYLLABUS M-SCHEME

(Implements from the Academic year 2015-2016 onwards)

Course Name : All branches of Diploma in Engineering and Technology and Special Programmes except DMOP, HMCT and film & TV.

Subject Code : **30025**

Semester : II Semester

Subject Title : **ENGINEERING CHEMISTRY – II**

#### TEACHING AND SCHEME OF EXAMINATION:

No. of Weeks per Semester: 15 Weeks

Subject	Instructions		Examination			Duration
	Hours/ Week	Hours/ Semester	Marks			
			Internal Assessment	Board Examination	Total	
ENGINEERING CHEMISTRY - II	5	75	25	75	100	3 Hrs

#### Topics and Allocation of Hours:

Sl. No	Topics	Time (Hours)
1	Environmental Chemistry	13 Hours
2	Fuels, Combustion and Refractories	13 Hours
3	Extraction of metals, Powder Metallurgy, Alloys and Abrasives	13 Hours
4	Cement, Ceramics, Lubricants and Adhesives	13 Hours
5	Polymer Chemistry	13 Hours
	Revision and Examinations	10 Hours
<b>Total</b>		<b>75 Hours</b>

#### **RATIONALE:**

Modern development of industries require more understanding of materials required for Engineering and industrial purposes. This part of chemistry explains various aspects with regard to environment, fuels, metals and alloys and polymers. This subject will develop basic understanding and skill of Engineering Students.

#### **OBJECTIVES:**

The objective of this Course is to make the student:

1. To acquire knowledge about Environmental Chemistry.
2. To acquire knowledge about fuels, advantages and combustion of fuels and analysis and refractories.
3. To know about extraction of metals, powder metallurgy, alloys, and abrasives.
4. To acquire knowledge about cement, ceramics, lubricants and adhesives.
5. To know about polymer materials.



**30025 ENGINEERING CHEMISTRY – II**  
**DETAILED SYLLABUS**

**Contents: Theory**

Unit	Name of the Topic	Hours
<b>I</b>	<p><b>ENVIRONMENTAL CHEMISTRY</b></p> <p><b>1.1 Air Pollution</b> Pollution and Air pollution – Definition – Air pollutants (SO<sub>2</sub>, H<sub>2</sub>S, HF, CO and Dust) – Sources and Harmful effects – Formation of Acid Rain – Harmful effects – Green House Effect – Causes – Global warming – Harmful effects – Ozone Layer – Importance – Causes for Depletion of Ozone Layer (No equations) – Harmful effects of Ozone Layer Depletion – Control of Air Pollution.</p> <p><b>1.2 Water Pollution</b> Causes of Water Pollution – Sewage, Effluents, Algae and Microorganisms – Harmful effects – Sewerage – Definition – Sewage Disposal – Industrial Effluents – Harmful effects of Effluents – Harmful effects of Heavy Metal Ions – Lead, Cadmium, Zinc and Copper – Treatment of Effluents – Eutrophication – Definition and harmful effects.</p> <p><b>1.3 Solid Waste Management</b> Solid Waste – Definition – Problems – Types of Solid Waste – Methods of disposal – Land fill and Incineration.</p> <p><b>1.4 Green Chemistry</b> Definition – Goals of Green Chemistry (Basic ideas) – Recycling – Definition – Examples – Advantages of Recycling (Basic ideas)</p>	<p><b>5 Hrs</b></p> <p><b>4 Hrs</b></p> <p><b>2 Hrs</b></p> <p><b>2 Hrs</b></p>
<b>II</b>	<p><b>FUELS, COMBUSTION AND REFRACTORIES</b></p> <p><b>2.1 Fuels</b> Fuel and fossil fuel – Definition – Calorific value – Classification of fuels – Solid fuels – Wood – Coal – Varieties of Coal – Composition – Specific uses – Liquid fuels – Petroleum – Fractional distillation – Fractions and uses – Cracking (Concept only) – Liquid Hydrogen as fuel – Gaseous fuels – Preparation, composition and specific uses of Producer gas and Water gas – Composition and uses of CNG and LPG – Relative advantages of solid, liquid and gaseous fuels.</p> <p><b>2.2 Combustion</b> Definition – Combustion calculation by mass (for solid and liquid fuels) – Combustion calculation by volume (for gaseous fuels) – Stoichiometric calculations – Volume of air required – Excess air – Definition of Flue gas – Flue gas Analysis – Orsat Apparatus – Simple numerical problems.</p> <p><b>2.3 Refractories</b> Definition – Requirements of a good Refractory – Classification – Acidic, Basic and Neutral Refractories – Examples and uses – Uses of Fireclay bricks, Alumina bricks and Silica bricks.</p>	<p><b>6 Hrs</b></p> <p><b>5 Hrs</b></p> <p><b>2 Hrs</b></p>

Unit	Name of the Topic	Hours
III	<p><b>EXTRACTION OF METALS, POWDER METALLURGY, ALLOYS AND ABRASIVES</b></p> <p><b>3.1 Extraction of metals</b> Extraction of Tungsten and Titanium – Uses of Tungsten and Titanium.</p> <p><b>3.2 Powder metallurgy</b> Definition – Preparation of Metal Powder – Atomization – Reduction of Metal Oxide – Applications of Powder Metallurgy.</p> <p><b>3.3 Alloys</b> Definition – Purpose of alloying – Types – Ferrous Alloys – Composition and uses of Stainless Steel, Chromium Steel and Vanadium Steel – Non-ferrous alloys – Composition and uses of Nichrome, Dutch metal, German silver, Gun metal and Duralumin.</p> <p><b>3.4 Abrasives</b> Definition – Classification – Hardness in Moh's scale – Natural abrasives – Diamond, Corundum, Emery and Garnet – Synthetic abrasives – Carborundum – Boron carbide – Manufacture – Properties and uses.</p>	<p><b>2 Hrs</b></p> <p><b>3 Hrs</b></p> <p><b>4 Hrs</b></p> <p><b>4 Hrs</b></p>
IV	<p><b>CEMENT, CERAMICS, LUBRICANTS AND ADHESIVES</b></p> <p><b>4.1 Cement</b> Definition – Manufacture of Portland Cement – Wet Process – Setting of Cement (No equation).</p> <p><b>4.2 Ceramics</b> White pottery – Definition – Manufacture of White pottery – Uses – Definition of glazing – Purpose – Method – Salt glazing.</p> <p><b>4.3 Lubricants</b> Definition – Characteristics of Lubricant – Types of Lubricants – Solid – Semi-solid – Liquid Lubricants .</p> <p><b>4.4 Adhesives</b> Definition – Requirements of good adhesives – Natural adhesive – Uses of Shellac, Starch, Asphalt – Synthetic adhesive – Uses of Cellulose Nitrate, PVC, Phenol-formaldehyde and Urea-formaldehyde.</p>	<p><b>3 Hrs</b></p> <p><b>3 Hrs</b></p> <p><b>3 Hrs</b></p> <p><b>4 Hrs</b></p>

Unit	Name of the Topic	Hours
V	<b>POLYMERS</b> <b>5.1 Plastics</b>	6 Hrs
	Plastics – Definition - Polymerization – Definition – Types of polymerization – Addition polymerization – Formation of Polythene – Condensation polymerization – Formation of Bakelite – Types of plastics – Thermoplastics and Thermoset plastics – Differences – Mechanical properties of plastics – Advantages of plastics over traditional materials (Wood and Metal) –Reinforced or filled plastics – Definition – Advantages – Applications – Polymers in Surgery – Biomaterials – Definition – Biomedical uses of Polyurethane, PVC, Polypropylene and Polyethylene.	
	<b>5.2 Rubber</b> Definition – Preparation from Latex – Defects of natural rubber– Compounding of rubber – Ingredients and their functions – Vulcanization – Definition and Purpose – Reclaimed rubber – Definition – Process – Properties and uses.	5 Hrs
<b>5.3 Composite materials</b> Definition – Examples – Advantages over metals and polymers – General applications.	2 Hrs	

Text Book:

1. Engineering Chemistry – Jain & Jain – Dhanpat Rai & Sons.
2. A Text Book of Engineering Chemistry – S.S. Dara – S. Chand Publication.

Reference Book:

1. Chemistry of Engineering Material-C.V. Agarwal, Andranaidu C. Parameswara Moorthy – B.S. Publications.
2. Engineering Chemistry – Uppal – Khanna Publishers.
3. A Text Book of Inorganic Chemistry – P.L. Soni – S. Chand Publication.
4. Rain Water Harvesting – Hand Book – Chennai Metro Water.

--oOo--

## Board Examination - Question paper pattern

**Time: 3 Hrs.**

**Max.Marks: 75**

**PART A** - 5 Questions to be answered out of **8** for 2 marks each.

**PART B** - 5 Questions to be answered out of **8** for 3 marks each.

**PART C** - All the **5** Questions to be answered

Each question in PART C will contain **3** Sub questions, out of these **3** Sub questions **2** Sub questions is to be answered for 5 marks each.

<b>PART A</b>	<b>5 x 2 marks</b>	<b>10 Marks</b>
<b>PART B</b> Short answer type questions	<b>5 x 3 marks</b>	<b>15 Marks</b>
<b>PART C</b> Descriptive answer type questions  Each question in PART C will contain <b>3</b> Sub questions, out of these <b>3</b> Sub questions <b>2</b> Sub questions is to be answered for 5 marks each.	<b>5 x 2 x 5 marks</b>	<b>50 Marks</b>
Total		<b>75 Marks</b>

Out of the **3 Sub questions** in **PART C**, **one sub question** must be on problem based to test the analytical ability/logical ability /diagnostic ability/conceptual ability relevant to that subject content. Equal weightage is to be given to whole syllabus.

Clarks table will not be permitted for the Board Examinations.

## ANNEXURE

### STATE BOARD OF TECHNICAL EDUCATION & TRAINING, TAMILNADU DIPLOMA IN ENGINEERING / TECHNOLOGY SYLLABUS

#### **M-SCHEME**

**(Implements from the Academic year 2015-2016 onwards)**

Course Name : All branches of Diploma in Engineering and Technology and Special Programmes except DMOP, HMCT and film & TV.

Subject Code : 30026

Semester : II Semester

Subject Title : ENGINEERING GRAPHICS – II

### TEACHING AND SCHEME OF EXAMINATION

No. of weeks per semester: 15 weeks

Subject	Instructions		Examination			Duration
	Hours / Week	Hours / Semester	Marks			
ENGINEERING GRAPHICS - II	6	90	Internal Assessment	Board Examination	Total	3 Hrs.
			25	75	100	

### **Topics and Allocation of Hours**

Sl.No.	Topics	Time (Hrs)
1	Constructions of special curves,	18 Hrs.
2	Development of surfaces	21 Hrs.
3	Projection of solids, Section of Solids	27 Hrs
4	Isometric projections	24 Hrs.
	<b>Total</b>	<b>90 Hrs.</b>

### **RATIONALE:**

Engineering graphics is a basic subject for all branches of Diploma Engineering and Technology. Since engineering drawing is considered as the language of engineers, the proper understanding and practice is required with proper instruments.

This subject is aimed at providing basic understanding of the fundamentals of Engineering Drawing; mainly visualization, graphics theory, standards & conventions of drawing, the tools of drawing and the use of Drawings in engineering applications.

The topics covered are based on the syllabus for Diploma studies in engineering. The subject is planned to include sufficient practices which would help the student in visualization of three dimensional objects and developing the drawing.

The chapters are arranged in sequence and starts from the basic concepts of constructions of special curves and polygons, proceeds to the principles of projection solids and section of solids. By the end of the subject it is expected that the students would be matured to visualize any engineering component by reading an engineering drawing.

**OBJECTIVES:**

At the end of the practice, the students will be able to,

- Understand the importance of drawing.
- Identify and uses of the drawing instruments.
- Acquire knowledge about the construction of special curves.
- Draw the development of solids and objects.
- Draw the projection and sectional views of solids and true shape.
- Construct orthographic views into isometric drawings.

**30026 ENGINEERING GRAPHICS – II**  
**DETAILED SYLLABUS**

**Contents: Theory**

Unit	Name of the Topic	Hours
I	<p><b>1.1 Constructions of special curves</b> Geometric curves: Definition - construction of cycloid - epicycloids – hypocycloid – exercises. Involute of a circle - Archimedean spiral – helix – exercises.</p> <p><b>1.2 Construction of Polygon</b> Construct triangle, rectangle, pentagon and hexagon by side distance in various positions – construction by inscribe &amp; circumscribe a circle and by angle.</p>	18
II	<p><b>2.1 Development of surfaces</b> Methods of development - Need for development - Development of regular polygons: prism, cylinder, cone and pyramids. Exercises in rectangular, pentagon and hexagon prisms and pyramids. Exercises in regular cylinder and cone. Development of truncated prism and cylinder, frustum of pyramid and cone. Development of miscellaneous objects - T-pipe, elbow, ducts, tray, lamp shade and funnel.</p>	21

III	<p><b>3.1 Projection of solids</b>  Introduction - important terms - classification of solids – polyhedron – solids of revolution – exercises in triangular and hexagonal prisms - triangular and hexagonal pyramids - cylinder and cone.  Projections of solids in simple positions – Axis parallel to one plane and perpendicular to other plane - axis inclined to one plane and parallel to other plane - axis parallel to both planes - exercises.</p> <p><b>3.2 Section of Solids</b>  Introduction – terminology - true shape - sectional view - need for sectional view - cutting plane – section lines - triangular and hexagonal prisms and pyramids - cylinder and cone.  Position of solids – Axis parallel to one plane and perpendicular to other plane - axis parallel to both planes - exercises.  Position of cutting planes – cutting plane perpendicular to one plane and parallel to another plane - cutting plane perpendicular to one plane and inclined to another plane – exercises.</p>	27
IV	<p><b>4.1 Isometric projections</b>  Introduction – isometric view - isometric projection – methods of drawing an isometric view - box method – isometric view of regular solids – isometric view of truncated solids - Isometric view of arcs and circles – four centre method for drawing an ellipse - arcs of circles in isometric view.  Isometric view of the machine parts from the given simple orthographic view - exercises.</p>	24

### Text Books

1. Bhatt N.D. and Panchal V.M., “Engineering Drawing”, Charotar Publishing House, 50<sup>th</sup> Edition, 2010.
2. Gill P.S., “Engineering drawing”, S.K.Kataria & Sons.

### Reference Books

1. Gopalakrishnan.K.R., "Engineering Drawing", (Vol.I and Vol.II), Dhanalakshmi publishers, Edition 2, 1970
2. Venugopal.K, Sreekanjana G, “Engineering Graphics” New Age International Publishers.
3. K V Nataraajan “A Text Book of Engineering Drawing”
4. Besant Agrawal, C M Agrawal “Engineering drawing”, Tata McGraw Hill Education Private Limited.
5. Barkinson & Sinha, "First Year Engineering Drawing", Pitman Publishers.

**Board Examination – Question pattern**

**Time: 3 Hrs.**

**Max.Marks: 75**

[Note: Answer all the questions in the drawing sheet only. Assume missing dimensions suitably]

**Part A**

Answer all questions. Each question carries five marks.

$$3 \times 5 = 15$$

**Note: Three questions will be asked. (1 to 3). One question each from UNIT I, II and III.**

[Construction of polygon, Development of regular polygon and Projection of solids (axis perpendicular to one plane)].

**Part B**

Answer any four questions. Each question carries fifteen marks.

$$4 \times 15 = 60$$

**Note: Six questions will be asked. Minimum one question from each unit.**

**TOTAL**

**75**

**Internal Marks**

Assignment drawings	-	10
Test	-	10
Attendance	-	5
<b>Total</b>	-	<b>25</b>



## ANNEXURE

**STATE BOARD OF TECHNICAL EDUCATION & TRAINING, TAMILNADU**  
**DIPLOMA IN ENGINEERING / TECHNOLOGY SYLLABUS**  
**M-SCHEME**  
**(Implements from the Academic year 2015-2016 onwards)**

Course Name: All Branches of Diploma in Engineering and Technology and Special Programmes except DMOP, HMCT and Film & TV

Subject Code : **30027**

Semester : II Semester

Subject Title : **ENGINEERING PHYSICS - II PRACTICAL**

### TEACHING AND SCHEME OF EXAMINATION:

**No. of Weeks per Semester: 15 Weeks**

Subject	Instructions		Examination			Duration
	Hours/ Week	Hours/ Semester	Marks			
			Internal Assessment/ Record	Board Examination	Total	
ENGINEERING PHYSICS - II PRACTICAL	2	30	25	75	100	3 Hours

### RATIONALE:

In Diploma level Engineering education skill development plays a vital role. The skill development can be achieved by on hand experience in handling various instruments, apparatus and equipment. This is accomplished by doing engineering related experiments in practical classes in various laboratories.

### GUIDELINES:

All the Eight experiments given in the list of experiments should be completed and given for the end semester practical examination.

- In order to develop best skills in handling Instruments/Equipment and taking readings in the practical classes, every two students should be provided with a separate experimental setup for doing experiments in the laboratory.
- The external examiners are requested to ensure that a single experimental question should not be given to more than four students while admitting a batch of 30 students during Board Examinations.

## 30027 ENGINEERING PHYSICS - II PRACTICAL

### LIST OF EXPERIMENTS WITH OBJECTIVES:

#### 1. REFRACTIVE INDEX

To determine the refractive index of a transparent liquid (water) using travelling Microscope.

#### 2. SPECTROMETER.

To measure the angle of the prism and the angle of minimum deviation using Spectrometer and to calculate the refractive index of glass.

#### 3. SOLAR CELL.

To draw the V – I characteristics of the solar cell.

#### 4. LAWS OF RESISTANCES.

To verify the laws of resistances by connecting the two given standard resistances

- (i) in series and
- (ii) in parallel, using Ohm's law.

#### 5. JOULE'S CALORIMETER.

To determine the specific heat capacity of water.

#### 6. COPPER VOLTAMETER.

To determine the electro chemical equivalent (e.c.e.) of copper.

#### 7. P-N JUNCTION DIODE.

To draw the voltage – current characteristics in forward bias and to find the 'dynamic Forward resistance' & 'knee voltage' from the graph.

#### 8. LOGIC GATES.

To find the output conditions for different combinations of the input for NOT gate and 2 inputs AND, OR, NAND & NOR logic gates, using IC chips. ( IC 7404 –NOT Gate, IC 7408 – AND Gate, IC 7432 – OR gate, IC 7400 – NAND Gate, IC 7402 – NOR Gate)

### ALLOCATION OF MARKS

Formula & Diagram	15 marks
Tabulation with proper units	10 marks
Observation (including taking readings)	35 marks
Calculation	10 marks
Result	05 marks
	-----
Total	75 Marks

## 30027 ENGINEERING PHYSICS - II PRACTICAL

### LIST OF EQUIPMENT

1. REFRACTIVE INDEX  
Travelling Microscope, Beaker with transparent liquid and Saw dust.
2. *SPECTROMETER.*  
Spectrometer, Sodium vapour lamp, Reading lens and Glass prism
3. *SOLAR CELL.*  
Solar cell Kit for drawing the V - I characteristics
4. *LAWS OF RESISTANCES.*  
Battery Eliminator, key, rheostat, ammeter, voltmeter, Connecting wires and two known standard resistances.
5. *JOULE'S CALORIMETER.*  
Joule's Calorimeter, Battery eliminator, Rheostat, Key, Ammeter, voltmeter, stop clock, thermometer, digital Balance and connecting wires.
6. *COPPER VOLTAMETER.*  
Copper Voltmeter, Battery eliminator, Rheostat, Key, Ammeter, stop clock, digital balance, emery sheet and Connecting wires.
7. *P-N JUNCTION DIODE.*  
P-N Junction Diode forward characteristics kit.
8. *LOGIC GATES.*  
Logic gates testing apparatus kit with bread board for Mounting ICs and Integrated circuit chips ( IC 7404 –NOTGate, IC 7408 – AND Gate, IC 7432 – OR gate, IC 7400 – NAND Gate, IC 7402 – NOR Gate)

=====

## 30027 ENGINEERING PHYSICS - II PRACTICAL

### MODEL QUESTION PAPER

1. Determine the refractive index of the given transparent liquid using traveling Microscope.
2. Draw the  $V - I$  characteristics of the solar cell.
3. Measure the angle of the prism and the angle of minimum deviation using Spectrometer and then calculate the refractive index of glass.
4. Verify the laws of resistances by connecting the two given standard resistances (i) in series and (ii) in parallel, using Ohm's law.
5. Determine the specific heat capacity of water, using Joule's calorimeter.
6. Determine the electro chemical equivalent (e.c.e.) of copper using Copper Voltmeter.
7. Draw the voltage – current characteristics of a P-N junction diode in forward bias and then find the 'dynamic forward resistance' & 'knee voltage' from the graph.
8. Find the output conditions for different combinations of the input for NOT gate and 2 inputs AND, OR, NAND & NOR logic gates using IC chips.

=====

**STATE BOARD OF TECHNICAL EDUCATION & TRAINING, TAMILNADU**  
**DIPLOMA IN ENGINEERING - SYLLABUS**  
**M-SCHEME**  
**(Implements from the Academic year 2015 - 2016 onwards)**

Course Name: All Branches of Diploma in Engineering and Technology and Special Programmes except DMOP, HMCT and Film & TV

Subject Code: **30028**

Semester : II Semester

Subject Title: **ENGINEERING CHEMISTRY – II PRACTICAL**

**SCHEME OF INSTRUCTIONS AND EXAMINATION:**

No. of Weeks per Semester: 15 Weeks

Subject	Instructions		Examination			Duration
	Hours/ Week	Hours/ Semester	Marks			
			Internal Assessment/ Record	Board Examination	Total	
ENGINEERING CHEMISTRY - II PRACTICAL	2	30	25	75	100	3 Hours

**OBJECTIVES:**

1. At the end of the program the student will be able to identify the acid and basic radical present in the given Inorganic simple salt.
2. To analyse the given effluent and to find out presence of heavy metal ion present it.
3. To study about the harmful effects of the metallic pollutant.

**30028 ENGINEERING CHEMISTRY – II PRACTICAL**

**CONTENTS**

**Intellectual Skills**

1. Studying the effect of heating on substances and reagents
2. Study of the reactions of the following radicals leading to qualitative analysis of the given Inorganic simple salt soluble in water or dilute acids
3. Studying the harmful effects of effluents

**Acid Radicals** : Carbonate, Chloride, Nitrate and Sulphate

**Basic Radicals** : Lead, Copper, Aluminium, Zinc, Barium, Calcium, Magnesium and Ammonium

**Motor Skills**

1. Handling the apparatus carefully
2. Awareness on Industrial safety

### I. Analysis of Inorganic simple salt (QUALITATIVE ANALYSIS)

Analysis of eight inorganic simple salts containing any one acid radical and basic radical without omitting any of the above mentioned radicals.

### II. Analysis of Effluent containing Lead, Cadmium, Copper and Zinc metal ions (EFFLUENT ANALYSIS)

Analysis of four effluents, each containing the above mentioned metal ions. Report on the metallic pollutant with procedure (Basic Radical Analysis Procedure) and their harmful effects.

## MODEL QUESTION PAPER

3 Hours

1. Analyse the given Inorganic simple salt and report the acid radical and basic radical present in it.
2. Analyse the given sample of effluent and report the metallic pollutant present in it with procedure and its harmful effects.

### SCHEME OF EVALUATION

FOR	MARKS
ANALYSIS OF SIMPLE SALT	46
ANALYSIS OF EFFLUENT	24
VIVA-VOCE	05
TOTAL	75

### I. QUALITATIVE ANALYSIS:

FOR	MARKS
Identification of Acid Radical with Systematic Procedure	23
Identification of Basic Radical with Systematic Procedure	23
Identification of Acid Radical with confirmatory test	10
Identification of Basic Radical with confirmatory test	10
Mere Spotting of Acid Radical and Basic Radical (3+3)	06

### II. EFFLUENT ANALYSIS:

FOR	MARKS
Identification of metallic pollutant with systematic procedure	20
Harmful effects of metallic pollutant	04
Group Identification Tests of metallic pollutant	10
Confirmatory Test of metallic pollutant	10
Mere Spotting of the pollutant	03

**List of Apparatus to be provided for each student in Chemistry Laboratory during the Engineering Chemistry – II Practical Classes/Board Examination in addition to the required Reagents:**

Sl.No.	Name of the Item	Quantity (Nos.)
1	Funnel	1
2	Glass Rod	1
3	Test Tubes (15 x 1.5 mm)	4
4	Test Tubes (15 x 1.5 mm)	1
5	Test Tube cleaning Brush	1
6	Test Tube Holder	1
7	Test Tube Stand	1
8	Wash Bottle	1

## FIRST YEAR ENGINEERING CHEMISTRY LABORATORY

### LIST OF EQUIPMENTS

#### LIST OF EQUIPMENTS REQUIRED FOR A BATCH OF 30 STUDENTS

##### NON-CONSUMABLE ITEMS

Sl.No.	Name of the Item	Quantity (Nos.)
1	LPG Connection	
2	Exhaust Fan (High Capacity)	Sufficient Nos.
3	Fire Extinguisher	1
4	First Aid Box (Full Set)	2
5	Safety Chart	1
6	Chemical Balance	1
7	Fractional Weight Box	1
8	pH Meter	5
9	Working Table with all accessories	8

##### GLASSWARE AND OTHER ITEMS

Sl.No.	Name of the Item	Quantity (Nos.)
1	Burette (50 ml)	35
2	Burette Stand	35
3	Pipette (20 ml) (With safety Bulb)	35
4	Pipette (10 ml)	5
5	Conical Flask (250 ml)	35
6	Funnel (3")	50
7	Porcelain Tile	35
8	Measuring Cylinder (10 ml)	5
9	Measuring Cylinder (1000 ml)	2
10	Reagent Bottle (White) (250 ml)	60
11	Reagent Bottle (White) (125 ml)	100
12	Reagent Bottle (Amber) (250 ml)	80
13	Test Tube (15 mm x 1.5 mm)	1000
14	Test Tube (15 mm x 2.5 mm)	500
15	Test Tube Stand	35
16	Test Tube Holder	35
17	Test Tube cleaning brush	35
18	Glass Trough	5
19	Beaker (100 ml)	35
20	Glass Rod (15 cm)	100
21	Watch Glass (3")	35
22	Wash Bottle (Polythene)	35
23	Nickel Spatula	35
24	Bunsen Burner for Gas connection	35
25	Plastic Bucket (15 L)	10
26	Filter Papers (Round)	Sufficient Nos.
27	Standard Flask (100 ml)	35